



# Measuring Instruments for Temperature





## Contents

### Measurement technology

Measurement technology for temperature measurement	4
Infrared temperature measurement and its applications	8

### Measuring instruments

Practical measuring instruments for contact measurements		Page
Thermometer strips	Self-adhesive foils	10
Clock indicators	Self-adhesive foils	10
Single indicators	Self-adhesive foils	11
Mini thermometer	Mini penetration thermometers	12
testo 905-T1	Penetration thermometer	13
testo 905-T2	Surface thermometer	13
Mini alarm thermometer	Mini thermometer with penetration probe and alarm	14
testo 106	The Compact Food Thermometer With Alarm	15
testo 105	Robust one-hand thermometer	15
testo 110	Multi-Purpose Highly Accurate Monitoring Thermometer	16
testo 112	Calibratable Temperature Measuring Instrument	18
testo 926	Fast, Accurate All-Round Thermometer	20
testo 925 / testo 922	Schnelle Temperaturmessung mit großem Messbereich	22
Ex-Pt 720	Highly accurate Ex-Pt thermometer	25
testo 720	Accurate Temperature Measurement	26
testo 735	Highly accurate temperature measuring instrument with data memory	28
testo 950	Highly accurate reference measuring instrument	32
Practical measuring instruments for non-contact measurements		Page
testo 810	Air temperature and infrared surface temperature in one instrument	39
testo 830-T1	Fast infrared thermometer with laser sighting (10:1 optics)	39
testo 830-T2	Infrared thermometer with 2-point laser sighting and probe socket (12:1 optics)	40
testo 830-T4	Infrared thermometer with 2-point laser marking and probe socket (30:1 optics)	41
testo 830-T3	Non-contact temperature measurement with close focus optics (2.5:1 optics)	42
testo 845	Infrared Thermometer with Switchable Optics (far-field/close focus)	43
testo 880	Thermal imager with highest image quality	46
testo 805	Mini infrared thermometer, pocket-size (1:1 optics)	48
testo 826-T1	Infrared food thermometer (6:1 optics)	49
testo 826-T2	Infrared food thermometer with laser sighting (6:1 optics)	49
testo 826-T3	Infrared thermometer with penetration probe (6:1 optics)	50
testo 826-T4	Infrared thermometer with penetration probe and laser sighting (6:1 optics)	50
testo 831	Distance thermometer for infrared monitoring measurements in the food sector (30:1 optics)	51
Measurement Data Monitoring System		Page
testo Saveris™	Measurement Data Monitoring System	52
Data loggers		Page
testo 174	Mini data logger	58
testo 175-T1	Compact data logger	59
testo 175-T2	Compact data logger with internal sensor and probe connection	60
testo 175-T3	2 external temperature probe sockets	62
testo 177-T1	Compact data logger with internal temperature sensor	64
testo 177-T2	Compact data logger with internal temperature sensor	65
testo 177-T3	Internal temperature sensor, 2 external temperature probe sockets and event logging	66
testo 177-T4	Compact data logger with 4 external temperature probe sockets	68
testostor 171-0	Pro data logger with internal temperature sensor	70
Ex 171-0	Data logger for Ex zone with an internal temperature sensor	71
testostor 171-1	Pro data logger with internal temperature sensor and one external temperature probe socket	72
testostor 171-4	Pro data logger with 4 external temperature probe sockets	74
testostor 171-8	Pro data logger with 4 external temperature probe sockets for high temperatures	76

### Accessories

Printer		Page
testo 575	Fast-action printer and logger control in one for testo 175/177	78
Accessories for data loggers		Page
testo 580	Compact data collector for testo 175/177 for on-site readout	79
testo 581	Alarm limit signal output for testo 175/177 to forward alarm messages	79
Software and accessories		Page
ComSoft 3 - Basic	User-friendly operation and convenient analysis	80
ComSoft 3 - Professional	Professional Software including Data Filing	81
ComSoft 3 - CFR 21 Part 11	Software for requirements in accordance with CFR 21 Part 11	81
Ethernet adapter	Access Ethernet with Testo measuring instruments	82

### Stationary measurement engineering

Stationary temperature probes	Overview standard probes	84
Configurator "Testo Celsius" on the internet	Temperature probe selection made easy	86
Custom temperature probes		89

### Option: Radio

Overview	Radio probes for testo 110, testo 926, testo 922, testo 925, testo 735	87
Ordering data	Radio probes for testo 110, testo 926, testo 922, testo 925, testo 735	88

## Sensor type selection

The probe type is determined by the measurement task. The selection of the most suitable temperature sensor is made according to the following criteria:

- Measurement range
- Accuracy
- Measurement site design
- Reaction time
- Durability

In order to be able to provide the right probe for your requirements, Testo offers a large selection of sensor elements and temperature measuring instruments:

- Thermocouples
- Resistance sensor (Pt100)
- Thermistors (NTC)

### Thermocouples

Temperature measurement with thermocouples is based on the thermoelectric effect.

Thermocouples consist of two wires spot-welded to each other and made of different metals or metal alloys. The basic values of the thermoelectric voltages and the permitted tolerances of thermocouples are defined in the norms IEC 584. The most common thermoelement is NiCr-Ni (type designation K).

### Resistance sensors (Pt100)

When measuring temperature with resistance sensors, use is made of the temperature sensitive resistance change in the platinum "resistance".

The measurement resistance is supplied with a constant current and the voltage drop, which changes with the resistance value via the temperature, is measured. Basic values and tolerances for resistance thermometers are defined in the IEC 751.

### Thermistors (NTC)

Temperature measurement with thermistors is also based on a temperature-dependent change of resistance in the sensor element. Contrary to resistance thermometers, thermistors have a negative temperature coefficient (resistance becomes smaller with increasing temperature). Characteristic curves and tolerances are not normed.

## Temperature measurement thermocouples

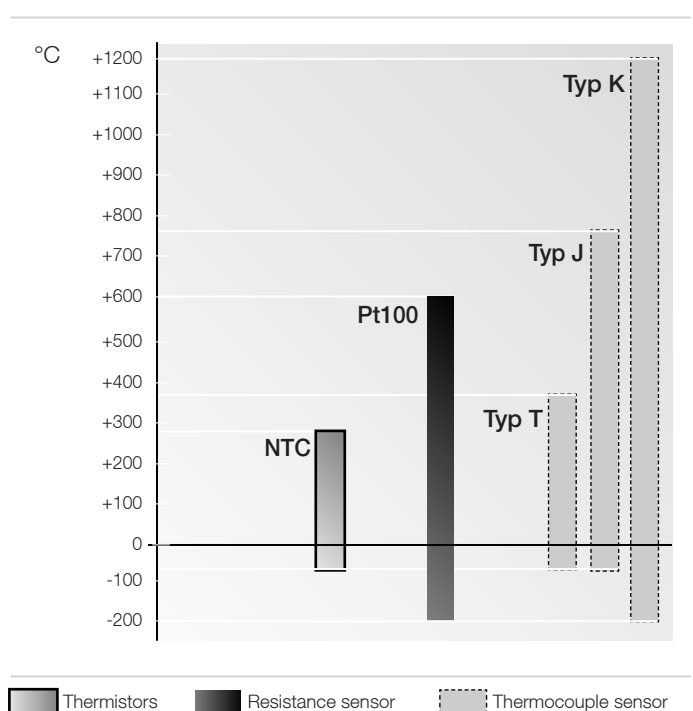

## Accuracy data

Measurement value sensor	Temperature range	Class	Permitted tolerances	
			fixed value	Referred to temperature
Thermocouple Typ K (NiCr-Ni)	-40 ... +1000 °C	1	±1.5 °C	±0.004 • Itl
	-40 ... +1200 °C	2	±2.5 °C	±0.0075 • Itl
	-200 ... +40 °C	3	±2.5 °C (-167 ... +40 °C)	±0.015 • Itl (-200 to -167.1 °C)
Typ T	-40 ... +350 °C	1	±0.5 °C	±0.001 • Itl
Typ J	-40 ... +750 °C	1	±1.5 °C	±0.004 • Itl
Pt100	-200 ... +600 °C	B	± (0.3 + 0.005 • Itl)	
	-200 ... +600 °C	A	± (0.15 + 0.002 • Itl)	
NTC (Standard)	-50 ... -25.1 °C	-	±0.4 °C	
	-25 ... +74.9 °C		±0.2 °C	
	+75 ... +150 °C		±0.5 % of full scale value	
NTC (High temp.)	-30 ... -20.1 °C	-	±1 °C	
	-20 ... 0 °C		±0.6 °C	
	+0.1 ... +75 °C		±0.5 °C	
	+75.1 ... +275 °C	- °C	±0.5 °C ±0.5 % of full scale value	

Itl = measurement temperature value

Data for thermocouples according to EN 60584-2 (formerly IEC 584-1).

Data for Pt100 according to EN 60751 (formerly IEC 751). No standardization exists for NTC sensors.

## Accuracy thermocouples

Data for thermocouples to EN 60584-2 (formerly IEC 584-1). Two values are given, one fixed value in °C and one formula. The larger value always applies.

For thermocouples of Class 1, the accuracies are specified for the measuring range -40 to +1000°C.

For thermocouples of Class 2, the accuracies apply for the measuring range -40 to +1200 °C

For thermocouples of Class 3, the accuracies apply for the measuring range -200 to +40.1 °C

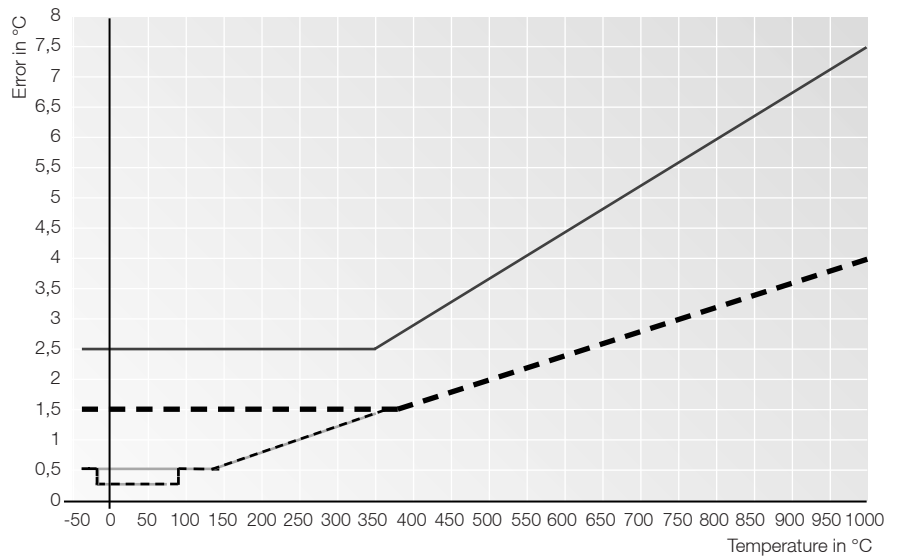

- - - Type J + Type K; Class 1 (Type J only up to +750 °C)    — Type T; Class 1  
 — Type J + Type K; Class 2 (Type J only up to +750 °C)    - - - Type T; Testo probe

## Accuracies Pt100/NTC

Data for Pt100 according to EN 60751 (formerly IEC 751). No standardization exists for NTC measurement values sensors.

In addition to fast and reliable thermocouple probes, Pt100 probes according to EN 60751 (formerly IEC 751) or selected high-precision probes based on Pt100 with 1/10 DIN accuracy are also available. These would precision sensors are 10 times more accurate than "normal" Pt100 sensors, which are already very accurate. Applied to Class B, whose error is  $\pm 0.3 + 0.005 \times I$  temperature I, this means an error of only  $\pm 0.03 + 0.0005 \times I$  temperature I.

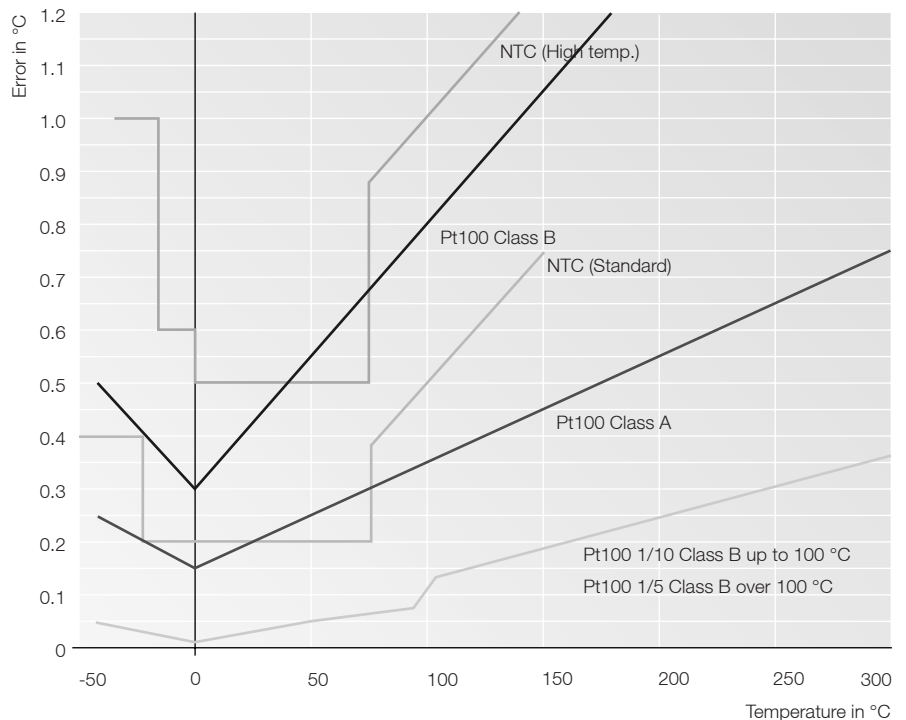

## Probe design selection

### Reaction time

$t_{99}$ -Time = Time until probe shows 99% of temperature change  
 $t_{99} = 4.6 \times t_{63}$  - Time  
 $t_{99} = 2 \times t_{90}$  - Time

### Immersion-penetration probe



Immersion probe (NiCr-Ni, Pt100, NTC) for measurements in liquids, but also for measurements in powdery substances or in air.



Penetration probes (NiCr-Ni, Pt100, NTC) for measurements in plastic or paste-like media.

### Information

- The specified reaction time  $t_{99}$  is measured in moving liquid (water) at 60 °C.
- Generally, the thinner the probe, the faster it is and the shallower the necessary immersion depth into the measurement object.
- In order to be able to assume the real temperature of the measurement object, the probe must be immersed into the measurement object at least 10 x the diameter of the probe (better still 15 x diameter).
- However: The thinner the probe, the more carefully it has to be handled.
- Thermocouple probes can be manufactured with a very small diameter (0.25 mm) and are therefore ideal for fast measurements and measurements made on small objects.
- Resistance sensors can be manufactured at low cost with a diameter of 2 mm, but are usually more accurate than thermocouple probes.

### Durability

The probe shaft of thermocouple probes is made of Inconel (2.4816). In all other designs, stainless steel V4A (1.4571) is used for the probe shaft. The high quality material used generally ensures sufficient resistance to corrosive substances. Testo offers glass-coated probes for applications in highly corrosive media.

## Air probes

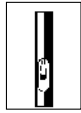

(NiCr-Ni, Pt100, NTC)  
In order to enable fast measurement, the sensor usually lies bare.

- The specified reaction time  $t_{99}$  is measured in a wind tunnel at 2 m/s and 60 °C.
- Immersion/penetration probes can also be used for air measurements. However, the reaction time is 40 to 60 times higher than the specified value which was measured in water.

## Surface probes

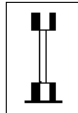

Design in NiCr-Ni, Cu-CuNi; Pt100; NTC probes. With a widened measurement tip for measurements on smooth, flat surfaces. For optimum heat transfer we recommend silicone conductive paste (Tmax 260 °C)

### Advantage:

- Robust design
- Higher sensor accuracy

### Disadvantage:

- Long reaction time
- Requires exact handling

Only suitable for smooth surfaces and objects with a high heat capacity, e.g. large metal objects.

### Information

- The specified reaction times  $t_{99}$  are measured on polished steel or aluminium plates at 60 °C.
- The specified accuracies are sensor accuracies.
- The accuracy in your application is dependent on the surface texture (roughness), the material of the measurement object (heat capacity and heat transfer) as well as the sensor accuracy. Testo provides the corresponding calibration certificate for the deviations of the measurement system in your application. For this purpose, Testo uses a surface test rig developed in cooperation with the German Federal Physical and Technical Institute (PTB).



Design in NiCr-Ni probes

Our recommendation for fast measurements, also on rough surfaces: Use the patented cross-band measurement head with a sprung thermocouple band. The cross-band takes on the actual temperature of the measurement object in only a few seconds:

- Easy handling  
(without silicon heat conductive paste)
- Fast measurement result

## What is heat radiation?

### Principles

It is a well-known fact in daily life that all bodies emit electromagnetic waves, or radiation, depending on their temperature. During dispersion of the radiation, energy is transported, a fact which means that radiation can be used to measure body temperature without contact. The radiated energy and its characteristic wavelengths are primarily dependent on the temperature of the radiating body. If, for example, you point a parabolic mirror with a match directly towards the sun, then it will ignite after a short period of time.

This is because of the heat radiation from the sun, which is concentrated by the parabolic mirror onto a point.

### Examples of heat radiation

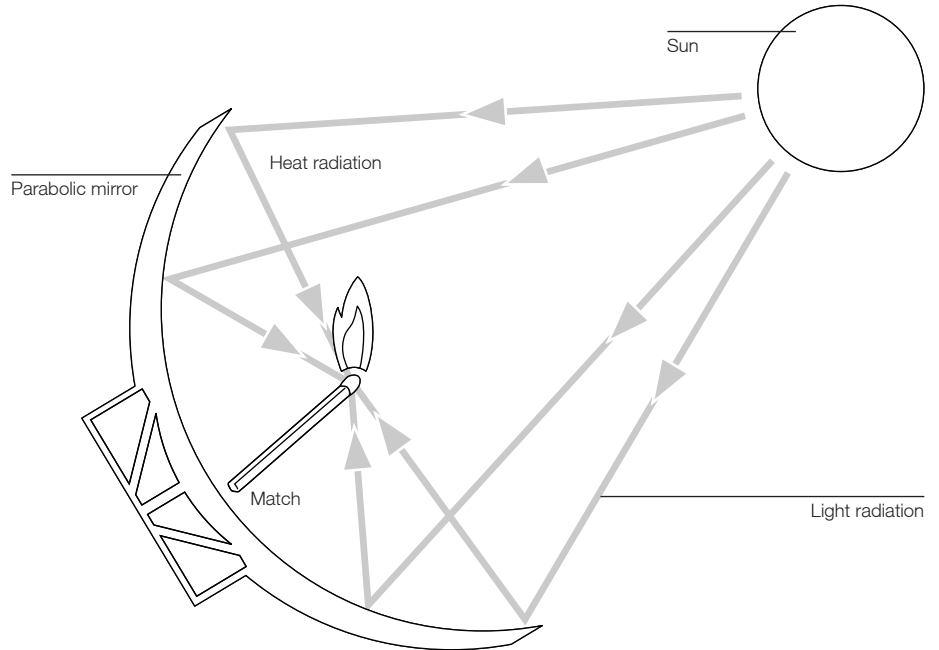

### Advantages of IR measuring technology

- > Infrared measuring technology enables simple temperature recording of fast, dynamic processes. This is assisted by the short reaction time of sensors and systems.
- > No influence on the object being measured means that measurements can be performed on sensitive surfaces and sterile products, just as well as measurements on hazardous points or points that are difficult to access.

### Infrared thermometers are particularly suitable for:

- > Poor heat conductors, such as ceramics, rubber, plastics etc. A probe for contact measurement can only display the correct temperature if it can take on the temperature of the measured body. In the case of poor heat conductors, this is not usually the case and/or the response times are very long.
- > Determining the surface temperature of gears, housings and bearings in large and small motors.
- > Moving parts, e.g. running paper webs, running sheet metal tracks etc.
- > Parts which cannot be touched, e.g. freshly painted parts, sterile parts or for corrosive substances.
- > Measuring very small and very large areas.
- > Live parts, e.g. electrical components, conductor rails, transformers etc.
- > Small and low-mass parts from which a contact probe would remove too much heat thus resulting in incorrect readings.



## Applications and practical tips

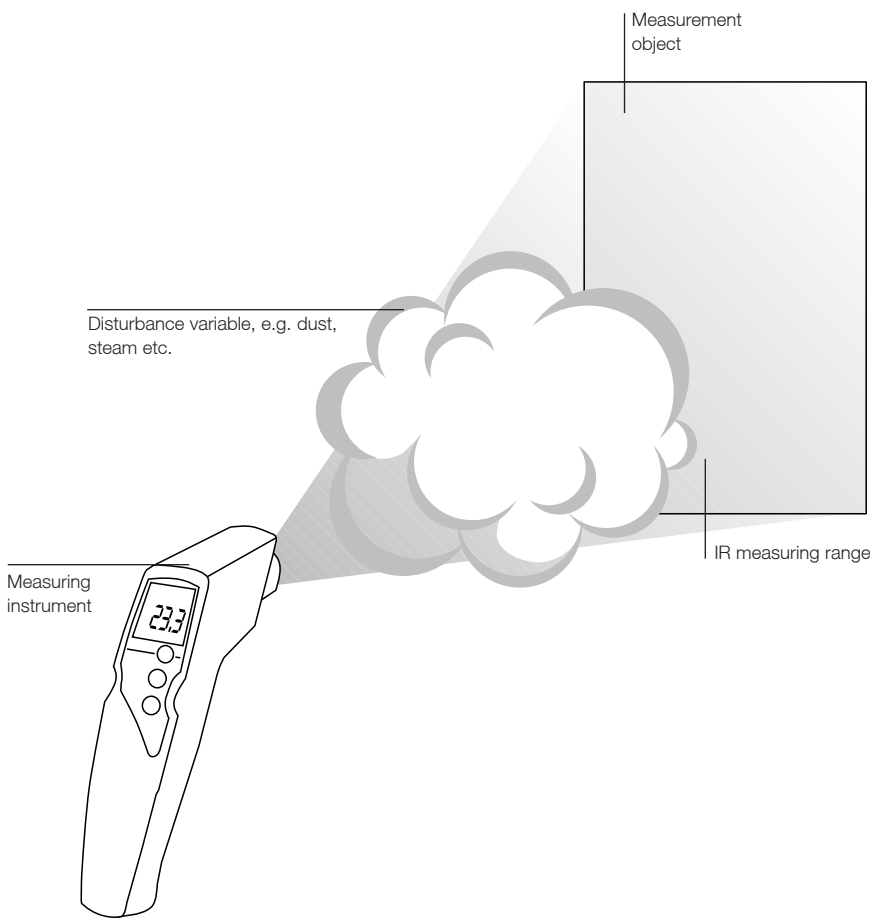

Emissivity table of important materials

Material	Temperature	E
Aluminium, bright-rolled	170 °C	0,04
Cotton	20 °C	0.77
Concrete	25 °C	0.93
Ice, smooth	0 °C	0.97
Iron, polished	20 °C	0.24
Iron with cast skin	100 °C	0.80
Iron with rolled skin	20 °C	0.77
Gypsum	20 °C	0.90
Glass	90 °C	0.94
Rubber, hard	23 °C	0.94
Rubber, soft grey	23 °C	0.89
Wood	70 °C	0.94
Cork	20 °C	0.70
Heat sink, black anodised	50 °C	0.98
Copper, lightly tarnished	20 °C	0.04
Copper, oxidised	130 °C	0.76
Plastics (PE, PP, PVC)	20 °C	0.94
Brass, oxidised	200 °C	0.61
Paper	20 °C	0.97
Porcelain	20 °C	0.92
Black paint (matt)	80 °C	0.97
Steel (heat-treated surface)	200 °C	0.52
Steel, oxidised	200 °C	0.79
Clay, fired	70 °C	0.91
Transformer paint	70 °C	0.94
Brick, mortar, plaster	20 °C	0.93

### Error sources with infrared measurement

In the case of non-contact temperature measurement, the composition of the transmission path between the instrument and the object being measured can also have an effect on the measured result.

#### Disturbance variables include, e.g.

- Dust and dirt particles
- Moisture (rain), steam, gases

> Only measure if there are no disturbing variables

### Incorrectly set, or too low emissivities can lead to significant errors.

- > Set emissivity using emissivity table or check via contact probe. A coating e.g. paint, oil or emission adhesive tape with a defined emissivity must be applied to the object being measured in the case of non-contact measurement on objects with low emissivity.

### The measuring instrument is not yet acclimatized to the new temperature after a temperature change (cold junction). This can lead to significant errors.

- > If possible, store the instrument in the place where the measurement is to be performed. This will avoid the problem of adjustment time (but observe instrument operating temperature).

### IR measurement is a purely optical measurement:

- > Clean lens is essential for accurate measurement.
- > Do not measure with fogged-up lens, e.g. due to steam

### IR measurement is surface measurement

- > Always make sure that the surface is clean. If there is dirt, dust, grime etc. on the surface, only the top layer will be measured.
- > Do not measure at occlusions (e.g. in packaging)

### Distance between IR measuring instrument and object being measured too far - measuring spot is bigger than object.

- > Keep distance between instrument and object being measured as small as possible.

## Thermometer strips

testoterm thermometer strips are self-adhesive foils with temperature sensitive elements for temperature control and regulation. Used, for example, for measurements on moving parts, for long-term monitoring and on small parts.

<b>+37 to +65 °C</b>
Part no. <b>0646 0108</b>
<b>+71 to +110 °C</b>
Part no. <b>0646 0916</b>
<b>+116 to +154 °C</b>
Part no. <b>0646 1724</b>
<b>+161 to +204 °C</b>
Part no. <b>0646 2532</b>
<b>+204 to +260 °C</b>
Part no. <b>0646 3341</b>
<b>+249 to +280 °C</b>
Part no. <b>0646 0005</b>

## Self-adhesive foils

- Irreversible change in colour within 2 seconds
- Practical booklet with 10 thermometer strips
- Thermometer strips available on rolls, from 5000 off

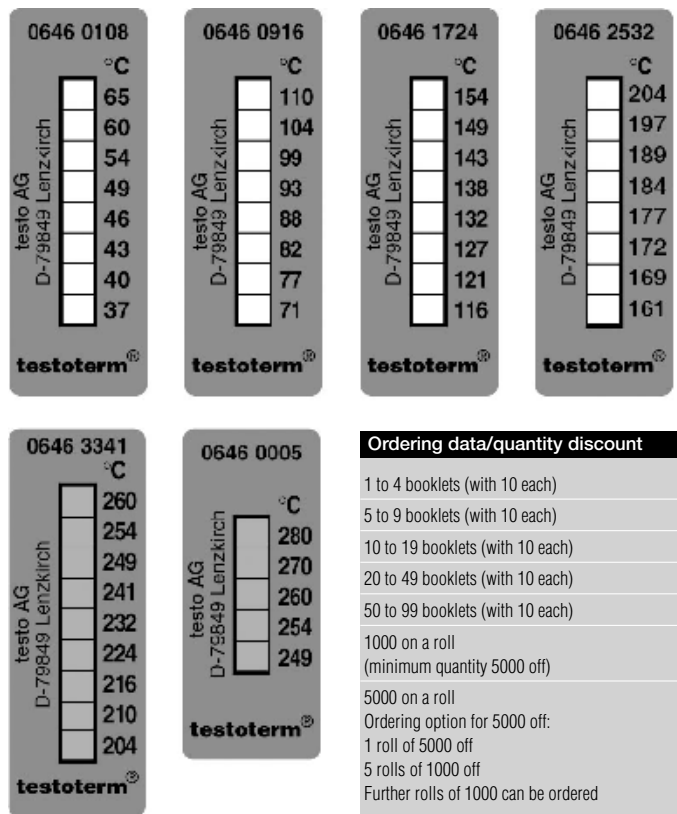

### Technical data

Accuracy: From +43°C to +154°C:  $\pm 1.5^\circ\text{C}$ ; from +160°C:  $\pm 1\% \pm 1^\circ\text{C}$  of respective temperature reading  
 Max. operating temperature corresponds to the respective measuring ranges  
 Storage of clock indicators: Up to +65°C, max. 9 months; other measuring ranges: up to 2 years; max. storage temperature +25°C. Storage in a refrigerator is recommended.  
 1 x w: 50 x 18 mm or 39 x 18 mm

### Ordering data/quantity discount

1 to 4 booklets (with 10 each)  
 5 to 9 booklets (with 10 each)  
 10 to 19 booklets (with 10 each)  
 20 to 49 booklets (with 10 each)  
 50 to 99 booklets (with 10 each)  
 1000 on a roll (minimum quantity 5000 off)  
 5000 on a roll  
 Ordering option for 5000 off:  
 1 roll of 5000 off  
 5 rolls of 1000 off  
 Further rolls of 1000 can be ordered

Actual size

## Clock indicators

testoterm clock indicators are self-adhesive, temperature proof foils with temperature sensitive elements for temperature control and regulation. They are particularly suitable for monitoring temperature in small objects.

<b>+40 to +54 °C</b>
Part no. <b>0646 0071</b>
<b>+60 to +82 °C</b>
Part no. <b>0646 0072</b>
<b>+88 to +110 °C</b>
Part no. <b>0646 0073</b>
<b>+116 to +138 °C</b>
Part no. <b>0646 0074</b>
<b>+143 to +166 °C</b>
Part no. <b>0646 0075</b>
<b>+171 to +193 °C</b>
Part no. <b>0646 0076</b>
<b>+199 to +224 °C</b>
Part no. <b>0646 0077</b>
<b>+232 to +260 °C</b>
Part no. <b>0646 0078</b>

## Self-adhesive foils



- Irreversible change in colour within 2 seconds
- Practical booklet with 10 clock indicators
- Clock indicators available on sheets from 5000 off (100 sheets of 50 off)

### Technical data

Accuracy: From +43°C to +154°C:  $\pm 1.5^\circ\text{C}$ ; from +160°C:  $\pm 1\% \pm 1^\circ\text{C}$  of respective temperature reading  
 Max. operating temperature corresponds to the respective measuring ranges  
 Storage of clock indicators: Up to +65°C, max. 9 months; other measuring ranges: up to 2 years; max. storage temperature +25°C. Storage in a refrigerator is recommended.  
 Ø 15 mm

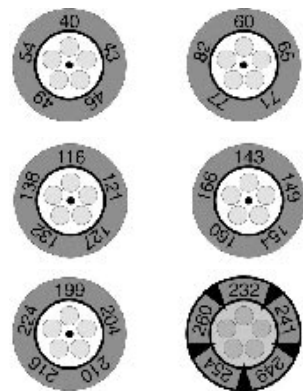

Actual size

### Ordering data/quantity discount

1 to 4 booklets (with 10 each)  
 5 to 9 booklets (with 10 each)  
 10 to 19 booklets (with 10 each)  
 20 to 49 booklets (with 10 each)  
 50 to 99 booklets (with 10 each)  
 1000 on sheets of 50 (Minimum quantity 5000 off)

## Single indicators

testoterm single indicators are self-adhesive temperature sensitive foils with elements used for control of a given maximum temperature.

### Single indicators

Measuring range: +43°C to +260°C

Part no. 0646 1... (...=reading)

Ordering examples:

Single indicator for +43°C: 0646 1043

Single indicator for +188°C: 0646 1188

- Irreversible change in colour within 1 second
- Practical single indicator booklet
- Single indicators available on rolls of 5000 or sheets

## Self-adhesive foils



### Ordering data/quantity discount

1 to 4 booklets (with 50 each)  
 5 to 9 booklets (with 50 each)  
 10 to 19 booklets (with 50 each)  
 20 to 49 booklets (with 50 each)  
 50 to 99 booklets (with 50 each)  
 5000 on rolls or sheets  
 Ordering option for 5000 off:  
 1 roll of 5000 off  
 5 rolls of 1000 off  
 Further rolls of 1000 can be ordered

In stock:

71 °C, 77 °C, 82 °C, 110 °C, 143 °C

Delivery time of 6 weeks for orders for more than 10 booklets of other single indicators (See Figure).

### Technical data

Accuracy: From +43°C to +154°C:  $\pm 1.5^\circ\text{C}$ ; from +160°C:  $\pm 1\% \pm 1^\circ\text{C}$  of respective temperature reading

Max. operating temperature corresponds to the respective measuring ranges

Storage of clock indicators: Up to +65°C, max. 9 months; other measuring ranges: up to 2 years; max. storage temperature +25°C. Storage in a refrigerator is recommended.

Larger quantities – Ask your Testo sales partner for more details.

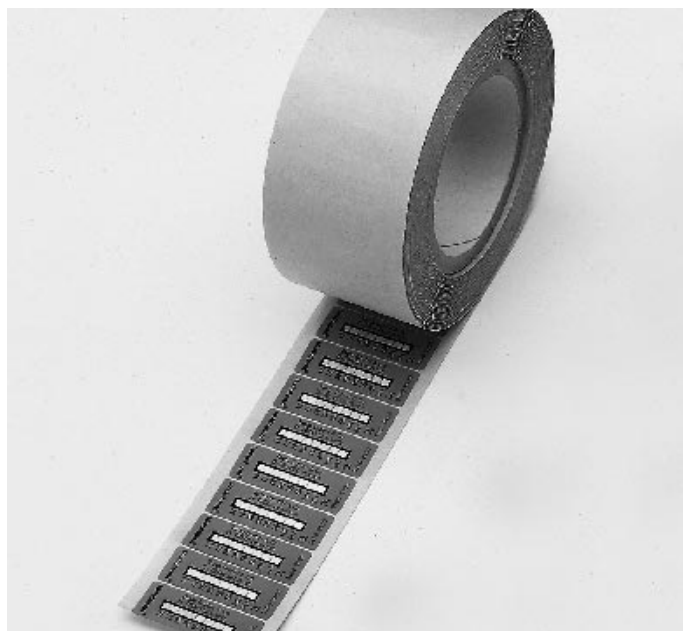

The delivery time for special quantities is 6 weeks.

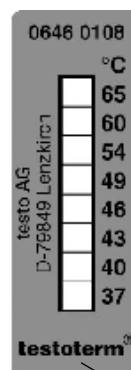

### Company name

You can have your company name or logo printed on the testoterm thermometer strips and testoterm single indicators if you order more than 10 000 (per temp. value).

Actual size



Your company name/logo can be printed here

## Mini thermometer

The quick-action immersion/penetration thermometer is ideal for measuring the temperature in air, soft or powdery substances and liquids.

**1** Mini thermometer, 133 mm long, up to +150°C

with protective sleeve for probe shaft

Part no.

**0560 1110**

**2** Mini thermometer, 213 mm long, up to +150°C

Part no.

**0560 1111**

**3** Water-proof mini thermometer

Protective sleeve for probe shaft

Part no.

**0560 1112**

Quantity discounts available

## Mini penetration thermometers

- Easy to read thanks to large display
- Can be used anywhere



Technical data			
	1	2	3
Meas. range	-50 to +150 °C	-50 to +250 °C	-40 to +230 °C
Accuracy	±1 °C (-10 to +99.9 °C)	±1 °C (-10 to +99.9 °C)	±1 °C (-20 to +99.9 °C)
±1 digit	±2 °C (-30 to -10.1 °C)	±2% of mv (+100 to +199.9 °C)	±2% of mv (+100 to +199.9 °C)
	±2% of mv (+100 to +150 °C)	±3% of mv (+200 to +250 °C)	±3% of mv (+200 to +230 °C)
Resolution	0.1 °C (-19.9 to +150 °C) 1 °C (remaining range)	0.1 °C (-19.9 to +199.9 °C) 1 °C (remaining range)	0.1 °C (-19.9 to +199.9 °C) 1 °C (remaining range)
Oper. temp.	-10 to +50 °C	-10 to +50 °C	-10 to +50 °C
Battery type	Button cell LR44	Button cell LR44	Button cell LR44
Display	LCD, 1 line	LCD, 1 line	LCD, 1 line
Warranty	2 years	2 years	2 years

Accessories	Part no.
Button cell batteries, Type LR 44, 1.5 Volt (4 off)	0515 0032

**testo 905-T1**
**Penetration thermometer**

testo 905-T1 is one of the fastest mini-thermometers, with a broad measuring range of -50 to +350 °C short-term (1-2 minutes) up to +500 °C. Especially in the higher measuring range, it has a considerably better accuracy than most thermometers in this price class.

- Broad measurement range
- High accuracy
- Easy readout of measurement value due to rotatable display
- Professional industrial sensor (thermocouple Type K)
- Large, fast display
- High temperature measurement, short-term up to 500 °C

**testo 905-T1: penetration thermometer incl. attachment clip, battery**

Part no.  
**0560 9055**

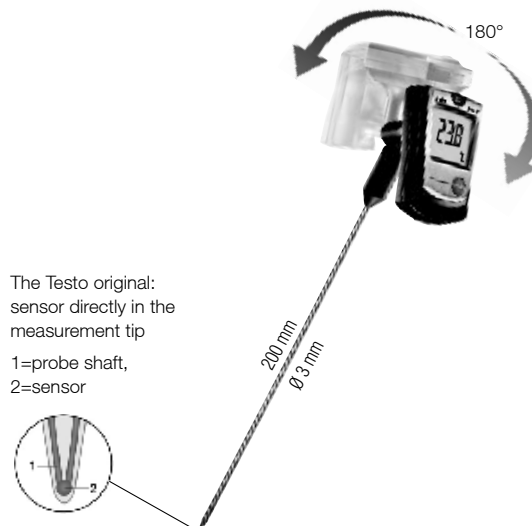

The Testo original: sensor directly in the measurement tip

1=probe shaft,  
2=sensor

**Technical data**

Meas. range	-50 to +350 °C Short-term to +500 °C
Accuracy ±1 digit	±1 °C (-50 to +99.9 °C) ±1% of mv (remaining range)
Resolution	0.1 °C
Oper. temp.	0 to +40 °C
Storage temp.	-20 to +70 °C

Battery type	3 batteries Type AAA
Battery life	1000 h
Reaction time	10 s
Reaction type	$t_{99}$ (in water)
Display	LCD, 1 line
Weight	80 g
Warranty	2 years

**Accessories**

	Part no.
ISO calibration certificate/temperature ; for air/immersion probes, calibration point 0°C	0520 0062
ISO calibration certificate/temperature ; for air/immersion probes, calibration point -18°C	0520 0061
ISO calibration certificate/temperature ; for air/immersion probes, calibration point +60°C	0520 0063
ISO calibration certificate/temperature ; for air/immersion probes, calibration points -18°C; 0°C; +60°C	0520 0001

**testo 905-T2**
**Surface thermometer**

testo 905-T2, the complete innovation. A surface thermometer in professional quality at the lowest price. The sprung thermocouple measurement head guarantees a very fast reaction time and high accuracy by always lying flat, even on rough surfaces.

- Very fast reaction time
- High accuracy
- Easy readout of readings due to rotatable display
- Very simple to operate
- Auto-Off function

**testo 905-T2: surface thermometer with cross-band probe, incl. attachment clip, battery**

Part no.  
**0560 9056**



Sprung thermocouple cross-band adapts to any surface

**Technical data**

Meas. range	-50 to +350 °C Short-term to +500 °C
Accuracy ±1 digit	±(1 °C ±1% of mv)
Resolution	0.1 °C
Oper. temp.	0 to +40 °C
Storage temp.	-20 to +70 °C

Battery type	3 batteries Type AAA
Battery life	1000 h
Reaction time	5 s
Reaction type	$t_{99}$
Display	LCD, 1 line
Weight	80 g
Warranty	2 years

**Accessories**

	Part no.
ISO calibration certificate/temperature ; single point calibration for surface thermometer; calibration point +120°C	0520 0073
ISO calibration certificate/temperature ; single point calibration for surface thermometer; calibration point +60°C	0520 0072
ISO calibration certificate/temperature ; meas. instr. with surface probe; calibration points +60°C; +120°C; +180°C	0520 0071
ISO calibration certificate/temperature ; meas. instruments with surface probe; calibration points selectable from -15 to +480°C	0520 0121

## Mini alarm thermometer

The affordable mini thermometer with Min/Max alarm. Small in size but big on quality! The penetration probe is attached to the instrument (80 cm cable) and is suitable for measuring the temperature in air, in soft, powdery substances and in liquids.

Mini thermometer, battery included

Part no.  
**0900 0530**

## Mini thermometer with penetration probe and alarm

- Permanently attached probe
- Adjustable Min/Max alarm
- With clip for positioning, for mounting on the wall and for attachment



### Ordering data/quantity discount

Mini thermometer, from 5 off
Mini thermometer, from 10 off
Mini thermometer, from 25 off
Mini thermometer, from 50 off

### Technical data

Meas. range	-50 to +150 °C
Accuracy	±1 °C (-10 to +100 °C) ±1 digit
Resolution	0.1 °C (-19.9 to +150 °C) 1 °C (-50 to -20 °C)
Oper. temp.	0 to +50 °C
Storage temp.	-20 to +70 °C

Battery type	2 AAA micro batteries
Battery life	100 h
Display	LCD, 1 line
Material/Housing	ABS
Warranty	2 years

### Accessories

Accessories	Part no.
ISO calibration certificate/temperature ; for air/immersion probes, calibration point -18°C	0520 0061
ISO calibration certificate/temperature ; for air/immersion probes, calibration point 0°C	0520 0062

**testo 106**
**The Compact Food Thermometer With Alarm**

The core thermometer testo 106 with a thin, robust measuring tip, excellently suited for fast core temperature monitoring in gastronomy, in hotels, large kitchens, supermarkets etc.

- TopSafe, waterproof and dishwasher-safe protective case (IP 67)
- Fast measurement (2 measurements per second)
- Almost invisible penetration hole due to special food probe
- Small, handy and always close to hand
- Automatic recognition of final value (Auto-Hold)

testo 106, core thermometer incl. probe protecting cap and battery

Part no.  
**0560 1063**



Only in combination with TopSafe

**Technical data**

Meas. range	-50 to +275 °C
Accuracy	±1 % of mv (+100 to +275 °C) ±0.5 °C (-30 to +99.9 °C) ±1 °C (-50 to -30.1 °C)
Resolution	0.1 °C
Oper. temp.	-20 to +50 °C
Storage temp.	-40 to +70 °C
Battery type	3V button cell (CR 2032)
Battery life	350 h
Dimensions	215 x 34 x 19 mm
Display	LCD, 1 line
Material/Housing	ABS
Weight	80 g
Protection class	IP 67 with TopSafe
Warranty	2 years

Set	Part no.	Accessories	Part no.
Set testo 106, core thermometer incl. TopSafe (waterproof protective case, IP 67), belt clip, probe protecting cover and battery	0563 1063	ISO calibration certificate/temperature ; for air/immersion probes, calibration point +60°C	0520 0063
		ISO calibration certificate/temperature ; for air/immersion probes, calibration point -18°C	0520 0061
		ISO calibration certificate/temperature ; for air/immersion probes, calibration point 0°C	0520 0062
		ISO calibration certificate/temperature ; for air/immersion probes, calibration points -18°C; 0°C	0520 0041
		ISO calibration certificate/temperature ; for air/immersion probes, calibration points -8°C; 0°C; +40°C	0520 0181
<b>Accessories</b>	<b>Part no.</b>		
Frozen food drill; loss-proof attachment to belt clip	0554 0826		
TopSafe (indestructible protection case); waterproof and dishwasher-safe protection case (IP67)	0516 8265		
Holding clip with probe protection cap	0554 0825		

**testo 105**
**Robust one-hand thermometer**

The robust food thermometer with interchangeable measurement tips for control measurements in abattoirs, refrigerated storerooms, lorries etc.

- 2 user-defined limit values, visual or audible alarm
- Built-in display illumination
- Audible key feedback
- 1 line display
- Waterproof (IP 65) and robust



testo 105, One-hand thermometer with standard measurement tip, incl. battery

Part no.  
**0563 1051**

**Technical data**

Meas. range	-50 to +275 °C
Accuracy	±0.5 °C (-20 to +100 °C) ±1 °C (-50 to -20.1 °C) ±1 % of mv (+100.1 to +275 °C)
Resolution	0.1 °C
Oper. temp.	-20 to +50 °C
Storage temp.	-40 to +70 °C
Battery type	4 x Button cell LR44
Battery life	80 h
Auto Off	10 min
Dimensions	145 x 38 x 195 mm
Display	LCD, 1 line
Weight	139 g
Protection class	IP65
Warranty	2 years

Set	Part no.	Accessories	Part no.
One-hand thermometer with standard measurement tip, frozen food tip, long measurement tip and belt/wall holder in aluminium case	0563 1052	1 Standard measurement tip, 100 mm long	0613 1051
		2 Frozen food tip, 90 mm long	0613 1052
		3 Long measurement tip, 200 mm long	0613 1053
testo 105 with frozen food measurement tip, belt/wall holder and batteries	0563 1054	Aluminium case for the testo 105 one-hand thermometer and accessories	0554 1051
		ISO calibration certificate/temperature, for air/immersion probes, calibration points -18°C; 0°C	0520 0041
		Button cell batteries, Type LR 44, 1.5 Volt (4 off)	0515 0032

## testo 110

## Multi-Purpose Highly Accurate Monitoring Thermometer

The highly accurate, versatile testo 110 temperature measuring instrument is ideal for applications in rough conditions on account of its protective case, TopSafe. The engineering used is specially designed for measurements in refrigerated store rooms, cabinets and for outdoors.

Minimum and maximum values are shown on a clear 2 line, backlit display or, if required, are printed on site on a Testo printer.

In addition to the wide range of standard handheld probes available (optional), a wireless radio probe can be used simultaneously.

- Wireless measurement with radio probes possible (optional)
- Measurement data printout on site on Testo printer (optional)
- TopSafe, the indestructible protective case (optional)
- Audible alarm (adjustable alarm limits)
- Minimum/maximum value memory
- Large backlit display
- Auto-Hold automatically recognises full-scale value



testo 110, 1 channel temperature measuring instrument NTC, audible alarm, connection to an optional radio probe, with battery and calibration protocol

Part no.  
**0560 1108**

Air probes	Illustration	Meas. range	Accuracy	t99	Part no.
<ul style="list-style-type: none"> <li>• Efficient, robust NTC air probe</li> </ul>	<p>115 mm 50 mm Ø 5 mm Ø 4 mm Conn.: Fixed cable 1.2 m</p>	-50 to +125 °C <sup>2)</sup>	±0.2 °C (-25 to +80 °C) ±0.4 °C (remaining range)	60 s	0613 1712
Surface probes	Illustration	Meas. range	Accuracy	t99	Part no.
<ul style="list-style-type: none"> <li>• Waterproof NTC surface probe for flat surfaces</li> </ul>	<p>115 mm 50 mm Ø 5 mm Ø 6 mm Conn.: Fixed cable 1.2 m</p>	-50 to +150 °C <sup>2)</sup>	±0.5% of mv (+100 to +150 °C) ±0.2 °C (-25 to +74.9 °C) ±0.4 °C (remaining range)	35 s	0613 1912
Pipe wrap probe with Velcro for pipe diameter to max. 75 mm, Tmax. +75 °C, NTC	<p>300 mm Conn.: Fixed cable</p>	-50 to +70 °C <sup>2)</sup>	±0.2 °C (-25 to +70 °C) ±0.4 °C (-50 to -25.1 °C)	60 s	0613 4611
Immers./penetr. probes	Illustration	Meas. range	Accuracy	t99	Part no.
<ul style="list-style-type: none"> <li>• Waterproof NTC immersion/penetration probe</li> </ul>	<p>115 mm 50 mm Ø 5 mm Ø 4 mm Conn.: Fixed cable 1.2 m</p>	-50 to +150 °C	±0.5% of mv (+100 to +150 °C) ±0.2 °C (-25 to +74.9 °C) ±0.4 °C (remaining range)	10 s	0613 1212
Food probes	Illustration	Meas. range	Accuracy	t99	Part no.
<ul style="list-style-type: none"> <li>• Stainless steel NTC food probe (IP65) with PUR cable</li> </ul>	<p>125 mm 15 mm Ø 4 mm Ø 3 mm Conn.: Fixed cable 1.6 m</p>	-50 to +150 °C <sup>2)</sup>	±0.5% of mv (+100 to +150 °C) ±0.2 °C (-25 to +74.9 °C) ±0.4 °C (remaining range)	8 s	0613 2211
<ul style="list-style-type: none"> <li>• Stainless steel NTC food probe (IP67) with Teflon cable to +250 °C</li> </ul>	<p>125 mm 15 mm Ø 4 mm Ø 3 mm Conn.: Fixed cable</p>	-50 to +150 °C <sup>2)</sup>	±0.5% of mv (+100 to +150 °C) ±0.2 °C (-25 to +74.9 °C) ±0.4 °C (remaining range)	8 s	0613 3311
<ul style="list-style-type: none"> <li>• Robust NTC food penetration probe with special handle, reinforced PUR cable</li> </ul>	<p>115 mm 30 mm Ø 5 mm Ø 3.5 mm Conn.: Fixed cable</p>	-25 to +150 °C <sup>2)</sup>	±0.5% of mv (+100 to +150 °C) ±0.2 °C (-25 to +74.9 °C) ±0.4 °C (remaining range)	7 s	0613 2411
<ul style="list-style-type: none"> <li>• Frozen food probe NTC, corkscrew design (incl. plug-in wire)</li> </ul>	<p>110 mm 30 mm Ø 8 mm Ø 4 mm Conn.: Plug-in cable</p>	-50 to +140 °C <sup>2)</sup>	±0.5% of mv (+100 to +140 °C) ±0.2 °C (-25 to +74.9 °C) ±0.4 °C (remaining range)	20 s	0613 3211

• The measuring instrument inside TopSafe is waterproof with this probe.

2) Long-term measurement range +125 °C, short-term +150 °C or +140 °C (2 minutes)



**testo 110**
**Accessories / Technical data**

Accessories	Part no.
<b>Accessories for measuring instrument</b>	
9V rech. battery for instrument instead of battery	0515 0025
Recharger for 9V rechargeable battery for external recharging of 0515 0025 battery	0554 0025
Lithium battery, button cell, type CR 2032 for wireless probes	0515 0028
<b>Printer and Accessories</b>	
Testo printer with wireless infrared interface, 1 roll of thermal paper and 4 AA batteries	0554 0547
Spare thermal paper for printer (6 rolls) measurement data documentation legible for up to 10 years	0554 0568
Spare thermal paper for printer (6 rolls)	0554 0569
External fast charger for 1-4 AA rech. batteries, incl. 4 Ni-MH rech. batteries with individual cell charging and charge control display, incl. impulse trickle charging, integrated discharge function, with built-in international mains plug, 100-240 V, 300 mA, 50/60 Hz	0554 0610
<b>Transport and Protection</b>	
TopSafe, protects from impact and dirt	0516 0221
Case for measuring instrument and probes	0516 0210
Transport case for meas. instr. and probes (405 x 170 x 85 mm)	0516 0201
Transport case for measuring instrument, 3 probes and accessories (430 x 310 x 85 mm)	0516 0200
<b>Calibration certificates</b>	
ISO calibration certificate/temperature for air/immersion probes, calibration points -18°C; 0°C; +60°C	0520 0001
ISO calibration certificate/temperature single point calibration for surface thermometer; calibration point +60°C	0520 0072
ISO calibration certificate/temperature single point calibration for surface thermometer; calibration point +120°C	0520 0073
DKD calibration certificate/temperature, meas. instr. with air/immersion probe; calibration points -20°C; 0°C; +60°C	0520 0211

Technical data		Probe type	NTC
Oper. temp.	-20 to +50 °C	Meas. range	-50 to +150 °C
Storage temp.	-40 to +70 °C	Accuracy ±1 digit	±0.2 °C (-20 to +80 °C) ±0.3 °C (remaining range)
Battery type	9V block battery, 6F22	Resolution	0.1 °C
Battery life	200 h (connected probe, backlight off) 45 h (radio mode, backlight off) 68 h (connected probe, backlight always on) 33 h (radio mode, backlight always on)		
Dimensions	182 x 64 x 40 mm		
Weight	171 g		
Material/Housing	ABS		
Warranty	2 years		

See back flap for radio probes

## testo 112

The calibratable testo 112 precision temperature measuring instrument was designed specially for official inspection measurements. The instrument is approved for official measurements by food inspectors, assessors and official authorities on account of its PTB design approval and the option of calibrating it. A built-in self-test indicates correct functioning before measurement begins.

Owing to its wide measuring range, testo 112 is the ideal temperature measuring instrument for all areas of food monitoring. NTC probes (thermistor probes) and Pt100 probes (platinum resistance probes) can both be attached to the probe input, so that a wide temperature range is covered, ranging from deep-frozen products to deep-fat fryer monitoring.

In order to document readings, testo 112 provides the possibility of printing data directly on site with date and time. This is particularly interesting for food hygiene inspectors. If adjustable high or low limit values are exceeded, the instrument immediately sounds an audible alarm.

Minimum and maximum limit values can be conveniently called up in the two-line display.

It is possible to print out readings on site on the Testo printer (optional).

**testo 112, 1 channel temperature measuring instrument NTC/Pt100, calibratable, with battery**

Part no.

**0560 1128**

## Calibratable Temperature Measuring Instrument

- The instrument for official food inspections
- Data printout on site on the Testo printer (optional)
- TopSafe, indestructible protection case (optional)
- Large, backlit display with 14 mm high characters
- Call up max/min values at the touch of a button
- Highly accurate, officially calibratable temperature measuring instrument
- Minimum/maximum value memory



Air probes	Illustration	Meas. range	Accuracy	t99	Part no.
<ul style="list-style-type: none"> <li>• Efficient, robust NTC air probe</li> </ul>	<p>Conn.: Fixed cable 1.2 m</p>	-50 to +125 °C <sup>2)</sup>	±0.2 °C (-25 to +80 °C) ±0.4 °C (remaining range)	60 s	0613 1712
Surface probes	Illustration	Meas. range	Accuracy	t99	Part no.
<ul style="list-style-type: none"> <li>• Waterproof NTC surface probe for flat surfaces</li> </ul>	<p>Conn.: Fixed cable 1.2 m</p>	-50 to +150 °C <sup>2)</sup>	±0.5% of mv (+100 to +150 °C) ±0.2 °C (-25 to +74.9 °C) ±0.4 °C (remaining range)	35 s	0613 1912
Pipe wrap probe with Velcro for pipe diameter to max. 75 mm, Tmax. +75 °C, NTC	<p>Conn.: Fixed cable</p>	-50 to +70 °C	±0.2 °C (-25 to +70 °C) ±0.4 °C (-50 to -25.1 °C)	60 s	0613 4611
Immersion/penetr. probes	Illustration	Meas. range	Accuracy	t99	Part no.
<ul style="list-style-type: none"> <li>• Waterproof NTC immersion/penetration probe</li> </ul>	<p>Conn.: Fixed cable</p>	-50 to +150 °C <sup>2)</sup>	±0.5% of mv (+100 to +120 °C) ±0.2 °C (-25 to +74.9 °C) ±0.4 °C (remaining range)	10 s	0613 1212
Food probes	Illustration	Meas. range	Accuracy	t99	Part no.
<ul style="list-style-type: none"> <li>• Stainless steel NTC food probe (IP65) with PUR cable</li> </ul>	<p>Conn.: Fixed cable</p>	-50 to +150 °C <sup>2)</sup>	±0.5% of mv (+100 to +150 °C) ±0.2 °C (-25 to +74.9 °C) ±0.4 °C (remaining range)	8 s	0613 2211
<ul style="list-style-type: none"> <li>• Stainless steel NTC food probe (IP67) with Teflon cable to +250 °C</li> </ul>	<p>Conn.: Fixed cable</p>	-50 to +150 °C <sup>2)</sup>	±0.5% of mv (+100 to +150 °C) ±0.2 °C (-25 to +74.9 °C) ±0.4 °C (remaining range)	8 s	0613 3311
<ul style="list-style-type: none"> <li>• Robust NTC food penetration probe with special handle, reinforced PUR cable</li> </ul>	<p>Conn.: Fixed cable</p>	-25 to +150 °C <sup>2)</sup>	±0.5% of mv (+100 to +150 °C) ±0.2 °C (-25 to +74.9 °C) ±0.4 °C (remaining range)	7 s	0613 2411
<ul style="list-style-type: none"> <li>• Frozen food probe NTC, corkscrew design (incl. plug-in wire)</li> </ul>	<p>Conn.: Plug-in cable</p>	-50 to +140 °C <sup>2)</sup>	±0.5% of mv (+100 to +140 °C) ±0.2 °C (-25 to +74.9 °C) ±0.4 °C (remaining range)	20 s	0613 3211

• The measuring instrument inside TopSafe is waterproof with this probe.

2) Long-term measurement range +125 °C, short-term +150 °C or +140 °C (2 minutes)

**testo 112**
**Accessories / Technical data**
**Calibratable probes**

Pt100	Illustration	Meas. range	Accuracy	t <sub>99</sub>	Part no.
♦ Waterproof Pt100 immersion/penetration probe, calibratable Conn.: Fixed cable 1.2 m		-50 to +300 °C	Class A	12 s	0614 1272
♦ Robust stainless steel Pt100 food probe !P65, calibratable Conn.: Fixed cable 1.2 m		-50 to +300 °C	Class A	10 s	0614 2272
NTC	Illustration	Meas. range	Accuracy	t <sub>99</sub>	Part no.
♦ Waterproof NTC immersion/penetration probe, calibratable Conn.: Fixed cable 1.2 m		-25 to +120 °C	±0.5% of mv (+100 to +120 °C) ±0.2 °C (-25 to +74.9 °C) ±0.4 °C (remaining range)	10 s	0614 1212
♦ Accurate, robust NTC air probe, calibratable Conn.: Fixed cable 1.2 m		-25 to +120 °C	±0.5% of mv (+100 to +120 °C) ±0.2 °C (-25 to +74.9 °C) ±0.4 °C (remaining range)	60 s	0614 1712
♦ Stainless steel NTC food probe (IP65) with PUR cable Conn.: Fixed cable		-25 to +120 °C	±0.5% of mv (+100 to +150 °C) ±0.2 °C (-25 to +74.9 °C) ±0.4 °C (remaining range)	8 s	0614 2211
♦ Robust NTC food penetration probe with special handle, reinforced PUR cable Conn.: Fixed cable		-25 to +120 °C	±0.5% of mv (+100 to +120 °C) ±0.2 °C (-25 to +74.9 °C) ±0.4 °C (remaining range)	7 s	0614 2411

♦ The measuring instrument inside TopSafe is waterproof with this probe.

Accessories	Part no.
<b>Accessories for measuring instrument</b>	
9V rech. battery for instrument instead of battery	0515 0025
Recharger for 9V rechargeable battery for external recharging of 0515 0025 battery	0554 0025
<b>Printer and Accessories</b>	
Testo printer with wireless infrared interface, 1 roll of thermal paper and 4 AA batteries	0554 0547
Spare thermal paper for printer (6 rolls) measurement data documentation legible for up to 10 years	0554 0568
Spare thermal paper for printer (6 rolls)	0554 0569
External fast charger for 1-4 AA rech. batteries, incl. 4 Ni-MH rech. batteries with individual cell charging and charge control display, incl. impulse trickle charging, integrated discharge function, with built-in international mains plug, 100-240 V, 300 mA, 50/60 Hz	0554 0610
<b>Transport and Protection</b>	
TopSafe, protects from impact and dirt	0516 0220
Case for measuring instrument and probes	0516 0210
Transport case for meas. instr. and probes (405 x 170 x 85 mm)	0516 0201
Transport case for measuring instrument, 3 probes and accessories (430 x 310 x 85 mm)	0516 0200

Technical data		
Probe type	NTC	Pt100
Meas. range	-50 to +120 °C	-50 to +300 °C
Accuracy ±1 digit	±0.2 °C (-25 to +40 °C) ±0.3 °C (+40.1 to +80 °C) ±0.5 °C (remaining range)	±0.2 °C (-50 to +200 °C) ±0.3 °C (remaining range)
Resolution	0.1 °C	0.1 °C
Oper. temp.	-20 to +50 °C	Dimensions 182 x 64 x 40 mm
Storage temp.	-30 to +70 °C	Weight 171 g
Battery life	100 h	Material/Housing ABS
Battery type	9V block battery, 6F22	Warranty 2 years

## testo 926

## Fast, Accurate All-Round Thermometer

The fast-action, efficient temperature measuring instrument, testo 926, for the food sector. The optional TopSafe protection case renders it insensitive to dirt, therefore making it the ideal partner for large-scale kitchens, hotels, restaurants or the food industry. Besides measuring minimum and maximum values, readings can also be printed on site on the Testo printer. In addition to the wide range of standard probes with cable, a wireless radio probe can be used simultaneously, if required.

- Measurement parameters °C, °F, °R
- Fast-action probes for every application
- Wireless measurement with radio probes possible (optional)
- Measurement data printout on site on the Testo printer
- TopSafe, the indestructible protection case (optional)
- Minimum/maximum value memory
- Large backlit display
- Auto-Hold automatically recognises full-scale value
- Audible alarm (adjustable alarm limits)



**testo 926-1, 1 channel food temperature measuring instrument T/C Type T, audible alarm, connection to an optional radio probe, with battery and calibration protocol**

Part no.  
**0560 9261**

### testo 926, Starter set

**testo 926, Starter set, 1 channel food temperature measuring instrument T/C Type T, incl. TopSafe, standard immersion/penetration probes, battery and calibration protocol**

Part no.  
**0563 9262**

Food probes	Illustration	Meas. range	Accuracy	t99	Part no.
● Robust food penetration probe with special handle, reinforced cable (PVC), T/C Type T	<p>115 mm Ø 5 mm 30 mm Ø 3.5 mm Conn.: Fixed cable</p>	-50 to +350 °C	±0.2 °C (-20 to +70 °C) Class 1 (remaining range)*	6 s	0603 2492
● Frozen food probe, corkscrew design, T/C Type T	<p>110 mm Ø 8 mm 30 mm Ø 4 mm Conn.: Plug-in cable</p>	-50 to +350 °C	±0.2 °C (-20 to +70 °C) Class 1 (remaining range)*	8 s	0603 3292
● Stainless steel food probe (IP67) with PUR cable, T/C Type T	<p>125 mm Ø 4 mm 30 mm Ø 3.2 mm Conn.: Fixed cable</p>	-50 to +350 °C	±0.2 °C (-20 to +70 °C) Class 1 (remaining range)*	7 s	0603 2192
Waterproof precision immersion/penetration probe without visible penetration hole, T/C Type T	<p>70 mm Ø 5 mm 15 mm Ø 1.5 mm Conn.: Fixed cable 1.2 m</p>	-50 to +350 °C	±0.2 °C (-20 to +70 °C) Class 1 (remaining range)*		0603 2693
● Stainless steel food probe (IP67), with Teflon cable to +250 °C, T/C Type T	<p>125 mm Ø 4 mm 30 mm Ø 3.2 mm Conn.: Fixed cable</p>	-50 to +350 °C	±0.2 °C (-20 to +70 °C) Class 1 (remaining range)*	7 s	0603 3392
● Waterproof, super-quick needle probe for measurements without visible penetration hole, T/C Type T	<p>150 mm Ø 1.4 mm 30 mm Ø 3.2 mm Conn.: Fixed cable</p>	-50 to +250 °C	±0.2 °C (-20 to +70 °C) Class 1 (remaining range)*	2 s	0628 0027
● Quick needle probe to monitor cooking in oven, T/C Type T	<p>60 mm Ø 1.4 mm 30 mm Ø 3.2 mm Conn.: Fixed cable</p>	-50 to +250 °C	±0.2 °C (-20 to +70 °C) Class 1 (remaining range)*	2 s	0628 0030
Measurement tip with T/C adapter Type T, ideal for fast-action measurement on incoming goods	<p>Ø 1.5 mm 500 mm Conn.: Fixed cable</p>	-50 to +350 °C	Class 1*	5 s	0628 0023
Flexible open probe, Tmax +250 °C, Teflon line	<p>2000 mm Ø 1.5 mm Conn.: Fixed cable</p>	-50 to +250 °C	Class 1*		0603 0646

● The measuring instrument inside TopSafe is waterproof with this probe.

\* According to standard EN 60584-2, the accuracy of Class 1 refers to -40 to +350 °C (Type T).

**testo 926**
**Accessories / Technical data**

Air probes	Illustration	Meas. range	Accuracy	t99	Part no.
Robust, affordable air probe, T/C Type T	 Conn.: Fixed cable 1.2 m	-50 to +350 °C	±0.2 °C (-20 to +70 °C) Class 1 (remaining range)*	25 s	0603 1793
Surface probes	Illustration	Meas. range	Accuracy	t99	Part no.
Waterproof surface probe with widened measurement tip for flat surfaces, T/C Type T	 Conn.: Fixed cable 1.2 m	-50 to +350 °C	±0.2 °C (-20 to +70 °C) Class 1 (remaining range)*	30 s	0603 1993
Immers./penetr. probes	Illustration	Meas. range	Accuracy	t99	Part no.
Waterproof standard immersion/penetration probe, T/C Type T	 Conn.: Fixed cable	-50 to +350 °C	±0.2 °C (-20 to +70 °C) Class 1 (remaining range)*	7 s	0603 1293

Accessories	Part no.
<b>Accessories for measuring instrument</b>	
9V rech. battery for instrument, instead of battery	0515 0025
Recharger for 9V rechargeable battery, for external recharging of 0515 0025 battery	0554 0025
<b>Printer and Accessories</b>	
Testo printer with wireless infrared interface, 1 roll of thermal paper and 4 AA batteries	0554 0547
Spare thermal paper for printer (6 rolls), measurement data documentation legible for up to 10 years	0554 0568
Spare thermal paper for printer (6 rolls)	0554 0569
External fast charger for 1-4 AA rech. batteries, incl. 4 Ni-MH rech. batteries with individual cell charging and charge control display, incl. impulse trickle charging, integrated discharge function, with built-in international mains plug, 100-240 V, 300 mA, 50/60 Hz	0554 0610
<b>Transport and Protection</b>	
TopSafe, protects from impact and dirt	0516 0220
Transport case for measuring instrument, 3 probes and accessories (430 x 310 x 85 mm)	0516 0200
Transport case for meas. instr. and probes (405 x 170 x 85 mm)	0516 0201
Case for measuring instrument and probes	0516 0210
<b>Calibration certificates</b>	
ISO calibration certificate/temperature for air/immersion probes, calibration points -18°C; 0°C; +60°C	0520 0001
ISO calibration certificate/temperature for air/immersion probes, calibration point -18°C	0520 0061
ISO calibration certificate/temperature for air/immersion probes, calibration point 0°C	0520 0062
ISO calibration certificate/temperature for air/immersion probes, calibration point +60°C	0520 0063
ISO calibration certificate/temperature for air/immersion probes, calibration points -8°C; 0°C; +40°C	0520 0181
ISO calibration certificate/temperature meas. instr. with surface probe; calibration points +60°C; +120°C; +180°C	0520 0071
ISO calibration certificate/temperature single point calibration for surface thermometer; calibration point +60°C	0520 0072
ISO calibration certificate/temperature single point calibration for surface thermometer; calibration point +120°C	0520 0073

Technical data			
Probe type	Type T (Cu-CuNi) or NTC and Type K if radio immersion/penetration probes are used	Oper. temp.	-20 to +50 °C
		Storage temp.	-40 to +70 °C
Parameters	°C, °F, °R	Battery type	9V block battery, 6F22
Meas. range	-50 to +400 °C	Battery life	200 h (connected probe, backlight off) 45 h (radio mode, backlight off) 68 h (connected probe, backlight always on) 33 h (radio mode, backlight always on)
Accuracy	±0.3 °C (-20 to +70 °C) ±(0.7 °C ±0.5% of mv) (remaining range)	Dimensions	182 x 64 x 40 mm
Resolution	0.1 °C (-50 to +199.9 °C) 1 °C (remaining range)	Material/Housing	ABS
		Weight	171 g
		Warranty	2 years

See back flap for radio probes

## testo 922

The differential thermometer records temperature values from 2 connected thermocouple probes and displays them simultaneously. The reading from an additional temperature probe can also be wirelessly displayed in the testo 922 measuring instrument; i.e. measurement data is transmitted by radio.

Differential temperature can be called up immediately. Current measurement data such as max/min data can be printed on the Testo printer on site. It is possible to print measurement data once a minute, for example, on the printer if cyclical printing is in operation.

**testo 922, 2 channel temperature measuring instrument T/C Type K, connection of an optional radio probe, with battery and calibration protocol**

Part no.  
**0560 9221**

## testo 925

The one channel temperature measuring instrument for connection to reliable, fast-action thermocouple probes. An additional temperature probe can be displayed in testo 925; data is transmitted by radio, i.e. wirelessly. An audible alarm sounds if limit values are exceeded. Current measurement data such as max/min data can be printed on site on the Testo printer.

**testo 925, 1 channel temperature measuring instrument T/C Type K, audible alarm, connection of an optional radio probe, with battery and calibration protocol**

Part no.  
**0560 9250**

## Fast Temperature Measurement with Wide Measurement Range

### Common Advantages testo 922, 925

- On site printout on Testo printer
- Continuous display of max/min values
- Hold button to freeze reading
- TopSafe, indestructible case, protects from dirt and impact (option)
- Display light

### testo 922

- 2 channel measuring instrument with optional radio probe
- Displays differential temperature
- Cyclical printing of readings, e.g. once a minute

### testo 925

- 1 channel measuring instrument with optional radio probe
- An audible alarm sounds when limit values are exceeded



Air probes	Illustration	Meas. range	Accuracy	t99	Part no.
● Robust air probe, T/C Type K	115 mm Ø 4 mm Conn.: Fixed cable 1.2 m	-60 to +400 °C	Class 2*	25 s	0602 1793
Immersion/penetr. probes	Illustration	Meas. range	Accuracy	t99	Part no.
● Efficient and fast-action immersion probe, waterproof, TC Type K	Ø 1.5 mm 300 mm Conn.: Fixed cable 1.2 m	-60 to +1000 °C	Class 1*	2 s	0602 0593
● Fast-action, waterproof immersion/penetration probe, TC Type K (Calibration not possible over +300 °C)	60 mm Ø 5 mm 14 mm Ø 1.5 mm Conn.: Fixed cable 1.2 m	-60 to +800 °C	Class 1*	3 s	0602 2693
Immersion tip, flexible, TC Type K	Ø 1.5 mm 500 mm	-200 to +1000 °C	Class 1*	5 s	0602 5792
Immersion measurement tip, flexible, for measurements in air/exhaust gases (not suitable for measurements in smelters), TC Type K	Ø 3 mm 1000 mm	-200 to +1300 °C	Class 1*	4 s	0602 5693
Immersion tip, flexible, TC Type K	Ø 1.5 mm 500 mm	-200 to +40 °C	Class 3*	5 s	0602 5793
● Waterproof immersion/penetration probe, TC Type K	114 mm Ø 5 mm 50 mm Ø 3.7 mm Conn.: Fixed cable 1.2 m	-60 to +400 °C	Class 2*	7 s	0602 1293

● The measuring instrument inside TopSafe is waterproof with this probe.

\*According to standard EN 60584-2, the accuracy of Class 1 refers to -40 to +1000 °C (Type K), Class 2 to -40 to +1200 °C (Type K), Class 3 to -200 to +40 °C (Type K).

**testo 922 / testo 925**
**Probes**

Surface probes	Illustration	Meas. range	Accuracy	t <sub>99</sub>	Part no.
<ul style="list-style-type: none"> <li>Fast-reaction paddle surface probe, for measurements in inaccessible places, e.g. narrow apertures and slots, TC Type K</li> </ul>	<p>Conn.: Fixed cable</p>	0 to +300 °C	Class 2*	5 s	0602 0193
<ul style="list-style-type: none"> <li>Fast-action surface probe with sprung thermocouple strip, also for uneven surfaces, measurement range short-term to +500°C, TC Type K</li> </ul>	<p>Conn.: Fixed cable 1.2 m</p>	-60 to +300 °C	Class 2*	3 s	0602 0393
<ul style="list-style-type: none"> <li>Waterproof surface probe with widened measurement tip for flat surfaces, T/C Type K</li> </ul>	<p>Conn.: Fixed cable 1.2 m</p>	-60 to +400 °C	Class 2*	30 s	0602 1993
<ul style="list-style-type: none"> <li>Fast-action surface probe with sprung thermocouple strip, bent, also for uneven surfaces, measurement range short-term to +500°C, TC Type K</li> </ul>	<p>Conn.: Fixed cable 1.2 m</p>	-60 to +300 °C	Class 2*	3 s	0602 0993
<ul style="list-style-type: none"> <li>Efficient, waterproof surface probe with small measurement head for flat surfaces, TC Type K</li> </ul>	<p>Conn.: Fixed cable 1.2 m</p>	-60 to +1000 °C	Class 1*	20 s	0602 0693
<ul style="list-style-type: none"> <li>Flat head surface probe with telescopic handle max. 680 mm for measurements at hard-to-access points, TC Type K</li> </ul>	<p>Conn.: Fixed cable</p>	-50 to +250 °C	Class 2*	3 s	0602 2394
<ul style="list-style-type: none"> <li>Magnetic probe, adhesive force approx. 20 N, with magnets, for measurements on metal surfaces, TC Type K</li> </ul>	<p>Conn.: Fixed cable</p>	-50 to +170 °C	Class 2*	150 s	0602 4792
<ul style="list-style-type: none"> <li>Magnetic probe, adhesive force approx. 10 N, with magnets, for higher temp., for measurements on metal surfaces, TC Type K</li> </ul>	<p>Conn.: Fixed cable</p>	-50 to +400 °C	Class 2*		0602 4892
<ul style="list-style-type: none"> <li>Pipe wrap probe with Velcro strip, for temperature measurement on pipes with diameter up to max. 120 mm, T<sub>max</sub> +120°C, TC Type K</li> </ul>	<p>Conn.: Fixed cable</p>	-50 to +120 °C	Class 1*	90 s	0628 0020
<ul style="list-style-type: none"> <li>Pipe wrap probe for pipe diameter 5 to 65 mm, with exchangeable measuring head. Meas. range short-term to +280°C, TC Type K</li> </ul>	<p>Conn.: Fixed cable</p>	-60 to +130 °C	Class 2*	5 s	0602 4592
<ul style="list-style-type: none"> <li>Spare meas. head for pipe wrap probe, TC Type K</li> </ul>		-60 to +130 °C	Class 2*	5 s	0602 0092
<ul style="list-style-type: none"> <li>Clamp probe for measurements on pipes, pipe diameter 15 to 25 mm (max. 1"), meas. range short-term up to +130°C, TC Type K</li> </ul>	<p>Conn.: Fixed cable</p>	-50 to +100 °C	Class 2*	5 s	0602 4692
Food probes	Illustration	Meas. range	Accuracy	t <sub>99</sub>	Part no.
<ul style="list-style-type: none"> <li>Waterproof food probe made of stainless steel (IP65), TC Type K</li> </ul>	<p>Conn.: Fixed cable</p>	-60 to +400 °C	Class 2*	7 s	0602 2292
<ul style="list-style-type: none"> <li>Robust food probe with special handle, IP 65, reinforced cable (PUR), T/C Type K</li> </ul>	<p>Conn.: Fixed cable</p>	-60 to +400 °C	Class 1*	6 s	0602 2492
<ul style="list-style-type: none"> <li>Waterproof robust immersion/penetration probe with metal protection hose T<sub>max</sub> +230°C, e.g. for monitoring temp. in cooking oil, T/C Type K</li> </ul>	<p>Conn.: Fixed cable</p>	-50 to +230 °C	Class 1*	15 s	0628 1292
Thermocouples	Illustration	Meas. range	Accuracy	t <sub>99</sub>	Part no.
<ul style="list-style-type: none"> <li>Thermocouple with TC adapter, flexible, 800mm long, fibre glass, TC Type K</li> </ul>		-50 to +400 °C	Class 2*	5 s	0602 0644
<ul style="list-style-type: none"> <li>Thermocouple with TC adapter, flexible, 1500mm long, fibre glass, TC Type K</li> </ul>		-50 to +400 °C	Class 2*	5 s	0602 0645
<ul style="list-style-type: none"> <li>Thermocouple with TC adapter, flexible, 1500mm long, Teflon, TC Type K</li> </ul>		-50 to +250 °C	Class 2*	5 s	0602 0646

\* The measuring instrument inside TopSafe is waterproof with this probe.\*According to standard EN 60584-2, the accuracy of Class 1 refers to -40 to +1000 °C (Type K), Class 2 to -40 to +1200 °C (Type K), Class 3 to -200 to +40 °C (Type K).

See back flap for radio probes

**testo 922 / testo 925 Accessories / Technical data**

Accessories	Part no.
<b>Accessories for measuring instrument</b>	
9V rech. battery for instrument instead of battery	0515 0025
Recharger for 9V rechargeable battery for external recharging of 0515 0025 battery	0554 0025
<b>Printer and Accessories</b>	
Testo printer with wireless infrared interface, 1 roll of thermal paper and 4 AA batteries	0554 0547
Spare thermal paper for printer (6 rolls) measurement data documentation legible for up to 10 years	0554 0568
<b>Transport and Protection</b>	
TopSafe, protects from impact and dirt (testo 922)	0516 0222
TopSafe, protects from impact and dirt (testo 925)	0516 0221
Transport case for measuring instrument, 3 probes and accessories (430 x 310 x 85 mm)	0516 0200
Transport case for meas. instr. and probes (405 x 170 x 85 mm)	0516 0201
Case for measuring instrument and probes	0516 0210
<b>Other features</b>	
Handle for attachable measurement tips (0602 5792/0644/0645/0646)	0409 1092
Extension cable, 5m, for thermocouple probe Type K	0554 0592
Silicone heat paste (14g), T <sub>max</sub> = +260°C improves heat transfer in surface probes	0554 0004

Accessories	Part no.		
<b>Calibration certificates</b>			
ISO calibration certificate/temperature for air/immersion probes, calibration points -18°C; 0°C; +60°C	0520 0001		
ISO calibration certificate/temperature** Meas. instr. with air/immersion probe; cal. points 0°C; +150°C; +300°C **(Applies only to immersion/penetration probe 0602 2693)	0520 0021		
ISO calibration certificate/temperature meas. instr. with air/immersion probe; calibration points 0°C; +300°C; +600°C	0520 0031		
ISO calibration certificate/temperature meas. instr. with surface probe; calibration points +60°C; +120°C; +180°C	0520 0071		
DKD calibration certificate/temperature meas. instr. with air/immersion probe; calibration points -20°C; 0°C; +60°C	0520 0211		
DKD calibration certificate/temperature contact surface temperature probes; calibration points +100°C; +200°C; +300°C	0520 0271		
<b>Technical data</b>			
<b>Probe type</b>	<b>Type K (NiCr-Ni)</b>	<b>Battery type</b>	9V block battery, 6F22
Meas. range	-50 to +1000 °C	<b>Battery life</b>	200 h (connected probe, backlight off) 45 h (radio mode, backlight off) 68 h (connected probe, backlight always on) 33 h (radio mode, backlight always on)
Accuracy ±1 digit	±(0.5 °C +0.3% of mv) (-40 to +900 °C) ±(0.7 °C +0.5% of mv) (remaining range)	<b>Dimensions</b>	182 x 64 x 40 mm
Resolution	0.1 °C (-50 to +199.9 °C) 1 °C (remaining range)	<b>Weight</b>	171 g
Oper. temp.	-20 to +50 °C	<b>Warranty</b>	2 years
Storage temp.	-40 to +70 °C		
Material/Housing	ABS		



## Ex-Pt 720

## Highly accurate Ex-Pt thermometer

Ex-Pt 720 for fast and accurate temperature measurements in hazardous areas up to Zone 0.

Ex-Pt 720 is the ideal measuring instrument for control measurements due to its wide measuring range and accurate four-wire technology.

Ex-Pt 720, temperature measuring instrument with holder strap, incl. battery and calibration protocol

Part no.  
**0560 7236**

- Highly accurate
- Wide range of probes
- Fast custom-designed probes service
- Approval in accordance with European and American Standards



Easy to read thanks to large display

**US Class I Div 1 ABCD T4**

Class 1 Zone 0 AEx ia IIC T4

**II 2(T) G EEx ia IIC T4**

TÜV 01 ATEX 1757 X

Probes	Illustration	Meas. range	Accuracy	t99	Part no.
Robust, water-proof immersion/penetration probe for Zone 1 and 2, PUR cable	<p>Conn.: Fixed cable</p>	-50 to +400 °C	Class A (-50 to +300 °C), Class B (remaining range)*	12 s	0628 1232
Robust, water-proof surface probe for Zone 1 and 2, with widened measuring tip for flat surfaces, PUR cable	<p>Conn.: Fixed cable</p>	-50 to +400 °C	Class B*	40 s	0628 1932
Robust immersion/penetration probe (IP 65) for Zone 0, 1 and 2, stainless steel, PUR cable can be used for up to +80°C, IP 54 plug-in connection	<p>Conn.: Fixed cable</p>	-50 to +400 °C	Class A (-50 to +300 °C), Class B (remaining range)*	10 s	0628 2232
Robust immersion probe (IP 67), for Zone 0, 1 and 2, stainless steel, FEP cable can be used at up to 205°C. Application: temperature measurement in petrol and oil tanks. Cable: 25 m long	<p>Conn.: Fixed cable</p>	-50 to +400 °C	Class A (-50 to +300 °C), Class B (remaining range)*	15 s	0628 2432

\*According to standard EN 60751, the accuracies of Class A and B refer to -200 to +600 °C (Pt100)

Accessories	Part no.
<b>Transport and Protection</b>	
Case for measuring instrument and probes	0516 0210
Transport case for meas. instr. and probes (405 x 170 x 85 mm)	0516 0201
Transport case for measuring instrument, 3 probes and accessories (430 x 310 x 85 mm)	0516 0200
<b>Calibration certificates</b>	
ISO calibration certificate/temperature, for air/immersion probes, calibration points -18°C; 0°C; +60°C	0520 0001
ISO calibration certificate/temperature, Meas. instr. with air/immersion probe; cal. points 0°C; +150°C; +300°C	0520 0021
ISO calibration certificate/temperature, meas. instr. with air/immersion probe; calibration points 0°C; +300°C; +600°C	0520 0031
DKD calibration certificate/temperature, meas. instr. with air/immersion probe; calibration points -20°C; 0°C; +60°C	0520 0211
DKD calibration certificate/temperature, Meas. instr. with air/immersion probe; cal. points 0°C; +100°C; +200°C	0520 0221
ISO calibration certificate/temperature, meas. instr. with surface probe; calibration points +60°C; +120°C; +180°C	0520 0071
DKD calibration certificate/temperature, contact surface temperature probes; calibration points +100°C; +200°C; +300°C	0520 0271

Technical data		
Probe type	Pt100	Oper. temp.
Meas. range	-50 to +400 °C	-10 to +50 °C
Accuracy	±0.2% of mv (+200 to +400 °C)	Storage temp.
±1 digit	±0.2 °C (-50 to +199.9 °C)	-20 to +70 °C
Resolution	0.1 °C (-50 to +199.9 °C)	Battery type
	1 °C (+200 to +400 °C)	9 V, IEC 6LR61
		Battery life
		100 h
		Dimensions
		190 x 57 x 42 mm
		Weight
		200 g
		Material/Housing
		Housing: ABS, coated
		Other features
		°C/°F
		Warranty
		2 years

## testo 720

## Accurate Temperature Measurement

Testo 720 is the single channel measuring instrument for demanding measurements in laboratories and in industry. Air, immersion and surface probes in a measurement range from -100 to +800 °C can be attached to the thermometer for different measuring tasks.

In combination with the indestructible TopSafe, testo 720 is resistant to corrosive media. The glass-coated probe has proved its worth in day-to-day use in the laboratory, as it too is resistant to corrosive media.

An audible alarm sounds when limit values are exceeded. Current measurement data, as well as min/max data can be printed out on site on the Testo printer.

- On site printout on Testo printer
- Continuous display of max/min values
- Hold button to freeze readings
- Display light
- Audible alarm (adjustable limit values)
- Resistant to corrosive media with TopSafe (optional)



testo 720, 1 channel temperature measuring instrument Pt100/NTC, with battery and calibration protocol

Part no.  
**0560 7207**

Laboratory probes	Illustration	Meas. range	Accuracy	t99	Part no.
Laboratory probe Pt100, glass-coated, exchangeable glass pipe (Duran 50), resistant to corrosive substances	<p>Fixed cable</p>	-50 to +400 °C	Class A (-50 to +300 °C), Class B (remaining range)*	45 s 12 s <sup>1)</sup>	0609 7072
<sup>1)</sup> Without protective glass					
Air probes	Illustration	Meas. range	Accuracy	t99	Part no.
● Efficient, robust NTC air probe	<p>Conn.: Fixed cable 1.2 m</p>	-50 to +125 °C	±0.2 °C (-25 to +80 °C) ±0.4 °C (remaining range)	60 s	0613 1712
● Efficient, robust air probe, Pt100	<p>Fixed cable</p>	-50 to +400 °C	Class A (-50 to +300 °C), Class B (remaining range)*	70 s	0609 1773
Surface probes	Illustration	Meas. range	Accuracy	t99	Part no.
● Waterproof NTC surface probe for flat surfaces	<p>Conn.: Fixed cable 1.2 m</p>	-50 to +150 °C	±0.5% of mv (+100 to +150 °C) ±0.2 °C (-25 to +74.9 °C) ±0.4 °C (remaining range)	35 s	0613 1912
Pipe wrap probe with Velcro for pipe diameter to max. 75 mm, Tmax. +75 °C, NTC	<p>Conn.: Fixed cable</p>	-50 to +70 °C	±0.2 °C (-25 to +70 °C) ±0.4 °C (-50 to -25.1 °C)	60 s	0613 4611
● Robust, waterproof surface temperature probe, Pt100	<p>Fixed cable</p>	-50 to +400 °C	Class B*	40 s	0609 1973
Immers./penetr. probes	Illustration	Meas. range	Accuracy	t99	Part no.
● Waterproof NTC immersion/penetration probe	<p>Conn.: Fixed cable</p>	-50 to +150 °C	±0.5% of mv (+100 to +150 °C) ±0.2 °C (-25 to +74.9 °C) ±0.4 °C (remaining range)	10 s	0613 1212
● Robust, waterproof Pt100 immersion/penetration probe	<p>Fixed cable</p>	-50 to +400 °C	Class A (-50 to +300 °C), Class B (remaining range)*	12 s	0609 1273

● The measuring instrument inside TopSafe is waterproof with this probe.

\*According to standard 60751, the accuracies of Class A and B refer to -200 to +600 °C (Pt100)

**testo 720**
**Accessories / Technical data**

Food probes	Illustration	Meas. range	Accuracy	t <sub>99</sub>	Part no.
<ul style="list-style-type: none"> <li>Stainless steel NTC food probe (IP65) with PUR cable</li> </ul>	<p>125 mm Ø 4 mm 15 mm Ø 3 mm</p> <p>Conn.: Fixed cable</p>	-50 to +150 °C <sup>2)</sup> -25 to +120 °C	±0.5% of mv (+100 to +150 °C) ±0.2 °C (-25 to +74.9 °C) ±0.4 °C (remaining range)	8 s	0613 2211
<ul style="list-style-type: none"> <li>Stainless steel NTC food probe (IP67) with Teflon cable to +250°C</li> </ul>	<p>125 mm Ø 4 mm 15 mm Ø 3 mm</p> <p>Conn.: Fixed cable</p>	-50 to +150 °C	±0.5% of mv (+100 to +150 °C) ±0.2 °C (-25 to +74.9 °C) ±0.4 °C (remaining range)	8 s	0613 3311
<ul style="list-style-type: none"> <li>Robust NTC food penetration probe with special handle, reinforced PUR cable</li> </ul>	<p>115 mm Ø 5 mm 30 mm Ø 3.5 mm</p> <p>Conn.: Fixed cable</p>	-25 to +150 °C <sup>2)</sup>	±0.5% of mv (+100 to +150 °C) ±0.2 °C (-25 to +74.9 °C) ±0.4 °C (remaining range)	7 s	0613 2411
<ul style="list-style-type: none"> <li>Frozen food probe NTC, corkscrew design (incl. plug-in wire)</li> </ul>	<p>110 mm Ø 8 mm 30 mm Ø 4 mm</p> <p>Conn.: Plug-in cable</p>	-50 to +140 °C <sup>2)</sup>	±0.5% of mv (+100 to +140 °C) ±0.2 °C (-25 to +74.9 °C) ±0.4 °C (remaining range)	20 s	0613 3211
<ul style="list-style-type: none"> <li>Robust, Pt100 stainless steel food probe (IP65)</li> </ul>	<p>125 mm Ø 4 mm 15 mm Ø 3 mm</p> <p>Fixed cable</p>	-50 to +400 °C	Class A (-50 to +300 °C), Class B (remaining range)*	10 s	0609 2272

◆ The measuring instrument inside TopSafe is waterproof with this probe.

2) Long-term measurement range +125°C, short-term +150°C or +140°C (2 minutes)

\*According to standard 60751, the accuracies of Class A and B refer to -200 to +600 °C (Pt100)

Accessories	Part no.
<b>Accessories for measuring instrument</b>	
9V rech. battery for instrument instead of battery	0515 0025
Recharger for 9V rechargeable battery for external recharging of 0515 0025 battery	0554 0025
<b>Printer and Accessories</b>	
Testo printer with wireless infrared interface, 1 roll of thermal paper and 4 AA batteries	0554 0547
Spare thermal paper for printer (6 rolls) measurement data documentation legible for up to 10 years	0554 0568
<b>Transport and Protection</b>	
TopSafe, protects from impact and dirt	0516 0221
Case for measuring instrument and probes	0516 0210
Transport case for meas. instr. and probes (405 x 170 x 85 mm)	0516 0201
Transport case for measuring instrument, 3 probes and accessories (430 x 310 x 85 mm)	0516 0200
<b>Other features</b>	
Silicone heat paste (14g), T <sub>max</sub> = +260°C improves heat transfer in surface probes	0554 0004
<b>Calibration certificates</b>	
ISO calibration certificate/temperature for air/immersion probes, calibration points -18°C; 0°C; +60°C	0520 0001
ISO calibration certificate/temperature Meas. instr. with air/immersion probe; cal. points 0°C; +150°C; +300°C	0520 0021
ISO calibration certificate/temperature meas. instr. with air/immersion probe; calibration points 0°C; +300°C; +600°C	0520 0031
DKD calibration certificate/temperature meas. instr. with air/immersion probe; calibration points -20°C; 0°C; +60°C	0520 0211
ISO calibration certificate/temperature meas. instr. with surface probe; calibration points +60°C; +120°C; +180°C	0520 0071
DKD calibration certificate/temperature contact surface temperature probes; calibration points +100°C; +200°C; +300°C	0520 0271

Technical data		
Probe type	Pt100	NTC
Meas. range	-100 to +800 °C	-50 to +150 °C
Accuracy ±1 digit	±0.2% of mv (+200 to +800 °C) ±0.2 °C (remaining range)	±0.2 °C (-25 to +40 °C) ±0.3 °C (+40.1 to +80 °C) ±0.4 °C (+80.1 to +125 °C) ±0.5 °C (remaining range)
Resolution	0.1 °C	0.1 °C
Oper. temp.	-20 to +50 °C	
Storage temp.	-30 to +70 °C	
Battery type	9V block battery	
Battery life	70 h	
Dimensions	182 x 64 x 40 mm	
Weight	171 g	
Material/Housing	ABS	
Warranty	2 years	

## testo 735-1

The robust and compact measuring instrument with a probe socket for highly accurate Pt100 probes and two sockets for fast-action thermocouple probes. Readings from up to three additional temperature probes can be shown on the instrument's clear display; measurement data transmission is by radio i.e. wireless. A total of six channels can be collected in this way by the instrument. Using the highly accurate, plug-in Pt100 immersion/penetration probe, a system accuracy of 0.05 °C with a resolution of 0.001 °C is reached. The measurement system is therefore ideally suited for use as a working standard. Data measured by testo 735-1 can be transmitted by infrared to the Testo printer for documentation purposes. If cyclical printing is used, it is also possible to print data on the printer once every minute, for example.

**testo 735-1, 3 channel temperature measuring instrument T/C Type K/T/J/S/Pt100, audible alarm, connection for max. 3 optional radio probes, incl. battery and calibration protocol**

Part no.  
**0560 7351**

## testo 735-2

The robust and compact measuring instrument with a probe socket for highly accurate Pt100 probes and two sockets for fast-action thermocouple probes. Readings from up to three additional temperature probes can be displayed in the testo 735-2 measuring instrument's clear display; data transmission is by radio, i.e. wireless. The measurement values can be simultaneously transferred to a PC and stored there. In this way, a total of 6 channels is recorded by the measuring instrument. A system accuracy of 0.05 °C with a resolution of 0.001 °C is reached using the plug-in highly accurate Pt100 immersion/penetration probe. The measuring instrument is therefore ideally suited for use as a working standard.

Temperature characteristics are recorded in the instrument and then analysed in graphics and tables on your PC/Notebook. Data is printed on site on the Testo printer using infrared.

Selectable user profiles, i.e. allocation of specific function buttons to an application facilitate intuitive and fast operation. Individual protocols or measurement series can be stored according to site. Up to 99 sites can be stored in the instrument. The storage cycle is user-defined between 0.5 seconds and 24 hours.

**testo 735-2, 3 channel temp. meas. instr. T/C Type K/T/J/S/Pt100, audible alarm, connection for max. 3 optional radio probes, with readings memory, PC software and USB data transmission cable, with battery and calibration protocol**

Part no.  
**0563 7352**

## Highly accurate temperature measuring instrument with data memory

- System accuracy up to 0.05 °C
- Testo printer prints measurement data on site (optional)
- Cyclical printing of readings once every minute, for example (testo 735-1)
- Instrument memory for 10,000 readings (testo 735-2)
- PC software for filing and documenting measurement data (testo 735-2)
- Displays, saves and prints Delta T, min, max and mean values
- Audible alarm when limit values are exceeded
- Protection class IP65
- Accuracy over the entire measurement range thanks to system adjustment
- The measurement values can be displayed in the instrument and simultaneously transferred to a PC and stored (testo 735-2)



Technical data			
Probe type	Pt100 with probe 0614 0235	Pt100	Type K (NiCr-Ni)
Meas. range	-40 to +300 °C	-200 to +800 °C	-200 to +1370 °C
Accuracy ±1 digit	See probe data	±0.2 °C (-100 to +199.9 °C) ±0.2% of mv (remaining range)	±0.3 °C (-60 to +60 °C) ±(0.2 °C + 0.3% of mv) (remaining range)
Resolution	0.001 °C (-40 to +199.999 °C) 0.01 °C (remaining range)	0.05 °C	0.1 °C
Battery life	Approx. 60 h	Approx. 250 h	Approx. 300 h
Probe type	Type T (Cu-CuNi)	Type J (Fe-CuNi)	Type S (Pt10Rh-Pt)
Meas. range	-200 to +400 °C	-200 to +1000 °C	0 to +1760 °C
Accuracy ±1 digit	±0.3 °C (-60 to +60 °C) ±(0.2 °C + 0.3% of mv) (remaining range)	±0.3 °C (-60 to +60 °C) ±(0.2 °C + 0.3% of mv) (remaining range)	±1 °C (0 to +1760 °C)
Resolution	0.1 °C	0.1 °C	1 °C
Battery life	Approx. 300 h	Approx. 300 h	Approx. 300 h
Oper. temp.	-20 to +50 °C	Protection class	IP65
Storage temp.	-30 to +70 °C	Dimensions	220 x 74 x 46 mm
Battery type	Alkali manganese, mignon, Type AA	Weight	428 g
		Material/Housing	ABS/TPE/Metal
		Warranty	2 years

**testo 735**
**Probes**

Laboratory probes	Illustration	Meas. range	Accuracy	t <sub>99</sub>	Part no.
Laboratory probe Pt100, glass-coated, exchangeable glass pipe (Duran 50), resistant to corrosive substances	<p>200 mm 30 mm Fixed cable Ø 6 mm Ø 5 mm</p>	-50 to +400 °C	Class A (-50 to +300 °C), Class B (remaining range)**	45 s 12 s <sup>1)</sup>	0609 7072  <sup>1)</sup> Without protective glass
<b>Air probes</b>	<b>Illustration</b>	<b>Meas. range</b>	<b>Accuracy</b>	<b>t<sub>99</sub></b>	<b>Part no.</b>
Robust air probe, T/C Type K	<p>115 mm Ø 4 mm Fixed cable</p>	-60 to +400 °C	Class 2*	25 s	0602 1793
Efficient, robust air probe, Pt100	<p>114 mm Ø 4 mm Fixed cable</p>	-50 to +400 °C	Class A (-50 to +300 °C), Class B (remaining range)**	70 s	0609 1773
Robust, affordable air probe, T/C Type T	<p>112 mm Ø 5 mm 50 mm Ø 4 mm Conn.: Fixed cable 1.2 m</p>	-50 to +350 °C	±0.2 °C (-20 to +70 °C) Class 1 (remaining range)*	25 s	0603 1793
<b>Surface probes</b>	<b>Illustration</b>	<b>Meas. range</b>	<b>Accuracy</b>	<b>t<sub>99</sub></b>	<b>Part no.</b>
Robust, waterproof surface temperature probe, Pt100	<p>114 mm Ø 5 mm Ø 9 mm Fixed cable</p>	-50 to +400 °C	Class B**	40 s	0609 1973
Fast-action surface probe with sprung thermocouple strip, also for uneven surfaces, measurement range short-term to +500°C, TC Type K	<p>115 mm Ø 5 mm Ø 12 mm Fixed cable</p>	-60 to +300 °C	Class 2*	3 s	0602 0393
Fast-reaction paddle surface probe, for measurements in inaccessible places, e.g. narrow apertures and slots, TC Type K	<p>145 mm Ø 8 mm 40 mm Ø 7 mm Conn.: Fixed cable</p>	0 to +300 °C	Class 2*	5 s	0602 0193
Efficient, waterproof surface probe with small measurement head for flat surfaces, TC Type K	<p>150 mm Ø 2.5 mm Ø 4 mm Fixed cable</p>	-60 to +1000 °C	Class 1*	20 s	0602 0693
Fast-action surface probe with sprung thermocouple strip, bent, also for uneven surfaces, measurement range short-term to +500°C, TC Type K	<p>80 mm Ø 5 mm 50 mm Ø 12 mm Fixed cable</p>	-60 to +300 °C	Class 2*	3 s	0602 0993
Flat head surface probe with telescopic handle max. 680 mm for measurements at hard-to-access points, TC Type K	<p>680 mm 12 mm Ø 25 mm Fixed cable</p>	-50 to +250 °C	Class 2*	3 s	0602 2394
Magnetic probe, adhesive force approx. 20 N, with magnets, for measurements on metal surfaces, TC Type K	<p>35 mm Ø 20 mm Fixed cable</p>	-50 to +170 °C	Class 2*	150 s	0602 4792
Magnetic probe, adhesive force approx. 10 N, with magnets, for higher temp., for measurements on metal surfaces, TC Type K	<p>75 mm Ø 21 mm Fixed cable</p>	-50 to +400 °C	Class 2*		0602 4892
Waterproof surface probe with widened measurement tip for flat surfaces, T/C Type K	<p>115 mm Ø 5 mm Ø 6 mm Fixed cable</p>	-60 to +400 °C	Class 2*	30 s	0602 1993
Pipe wrap probe with Velcro strip, for temperature measurement on pipes with diameter up to max. 120 mm, T <sub>max</sub> +120°C, TC Type K	<p>395 mm 20 mm Fixed cable</p>	-50 to +120 °C	Class 1*	90 s	0628 0020
Pipe wrap probe for pipe diameter 5 to 65 mm, with exchangeable measuring head. Meas. range short-term to +280°C, TC Type K	<p>35 mm Fixed cable</p>	-60 to +130 °C	Class 2*	5 s	0602 4592
Spare meas. head for pipe wrap probe, TC Type K	<p>15 mm Fixed cable</p>	-60 to +130 °C	Class 2*	5 s	0602 0092
Clamp probe for measurements on pipes, pipe diameter 15 to 25 mm (max. 1*), meas. range short-term up to +130°C, TC Type K	<p>15 mm Fixed cable</p>	-50 to +100 °C	Class 2*	5 s	0602 4692
Waterproof surface probe with widened measurement tip for flat surfaces, T/C Type T	<p>112 mm Ø 5 mm 50 mm Ø 6 mm Conn.: Fixed cable 1.2 m</p>	-50 to +350 °C	±0.2 °C (-20 to +70 °C) Class 1 (remaining range)*	30 s	0603 1993

\*According to standard EN 60584-2, the accuracy of Class 1 refers to -40 to +1000 °C (Type K), Class 2 to -40 to +1200 °C (Type K), Class 3 to -200 to +40 °C (Type K).

\*\*According to standard 60751, the accuracies of Class A and B refer to -200 to +600 °C (Pt100)

Immersion/penetr. probes	Illustration	Meas. range	Accuracy	t99	Part no.
Robust, waterproof Pt100 immersion/penetration probe	114 mm Fixed cable Ø 5 mm 50 mm Ø 3.7 mm	-50 to +400 °C	Class A (-50 to +300 °C), Class B (remaining range)**	12 s	0609 1273
Highly accurate Pt100 immersion/penetration probe with certificate	295 mm Fixed cable Ø 4 mm	-40 to +300 °C	±0.05 °C (+0.01 to +100 °C) ±(0.05 °C +0.05% of mv) (remaining range)	60 s	0614 0235
Efficient and fast-action immersion probe, waterproof, TC Type K	300 mm Fixed cable Ø 1.5 mm	-60 to +1000 °C	Class 1*	2 s	0602 0593
Fast-action, waterproof immersion/penetration probe, TC Type K	60 mm Fixed cable Ø 5 mm 14 mm Ø 1.5 mm	-60 to +800 °C	Class 1*	3 s	0602 2693
Immersion tip, flexible, TC Type K	500 mm Ø 1.5 mm	-200 to +1000 °C	Class 1*	5 s	0602 5792
Immersion tip, flexible, TC Type K	500 mm Ø 1.5 mm	-200 to +40 °C	Class 3*	5 s	0602 5793
Immersion measurement tip, flexible, for measurements in air/exhaust gases (not suitable for measurements in smelters), TC Type K	1000 mm Ø 3 mm	-200 to +1300 °C	Class 1*	4 s	0602 5693
Waterproof immersion/penetration probe, TC Type K	114 mm Fixed cable Ø 5 mm 50 mm Ø 3.7 mm	-60 to +400 °C	Class 2*	7 s	0602 1293
Flexible, low-mass immersion measurement tip, ideal for measurements in small volumes such as petri dishes, or for surface measurements (e.g. attached with adhesive tape), TC Type K	500 mm Ø 0.25 mm Conn.: 2 m, FEP insulated thermal wire, temperature proof up to 200 °C, oval wire with dimensions: 2.2 mm x 1.4 mm	-200 to +1000 °C	Class 1*	1 s	0602 0493
Thermocouples	Illustration	Meas. range	Accuracy	t99	Part no.
Thermocouple with TC adapter, flexible, 800mm long, fibre glass, TC Type K	800 mm Ø 1.5 mm	-50 to +400 °C	Class 2*	5 s	0602 0644
Thermocouple with TC adapter, flexible, 1500mm long, fibre glass, TC Type K	1500 mm Ø 1.5 mm	-50 to +400 °C	Class 2*	5 s	0602 0645
Thermocouple with TC adapter, flexible, 1500mm long, Teflon, TC Type K	1500 mm	-50 to +250 °C	Class 2*	5 s	0602 0646
Food probes	Illustration	Meas. range	Accuracy	t99	Part no.
Robust, Pt100 stainless steel food probe (IP65)	125 mm Fixed cable Ø 4 mm 15 mm Ø 3 mm	-50 to +400 °C	Class A (-50 to +300 °C), Class B (remaining range)**	10 s	0609 2272
Waterproof food probe made of stainless steel (IP65), TC Type K	125 mm Fixed cable Ø 4 mm 30 mm Ø 3.2 mm	-60 to +400 °C	Class 2*	7 s	0602 2292
Robust food probe with special handle, IP 65, reinforced cable (PUR), T/C Type K	115 mm Fixed cable Ø 5 mm 30 mm Ø 3.5 mm	-60 to +400 °C	Class 1*	6 s	0602 2492
Waterproof super-fast needle probe, highly accurate measurements without visible penetration hole. Specially for food, ideal for hamburgers, steaks, pizza, eggs etc., T/C Type K	150 mm Fixed cable Ø 1.4 mm 15 mm Ø 1 mm	-60 to +250 °C	Class 1*	1 s	0628 0026
Waterproof robust immersion/penetration probe with metal protection hose Tmax +230°C, e.g. for monitoring temp. in cooking oil, T/C Type K	240 mm Fixed cable Ø 4 mm	-50 to +230 °C	Class 1*	15 s	0628 1292
Stable, robust surface probe with PTFE standing area and metal protection hose Tmax +230°C for cooking surfaces, heating and baking trays, T/C Type K	120 mm Fixed cable Ø 60 mm	-50 to +230 °C	Class 2*	45 s	0628 9992

\*According to standard EN 60584-2, the accuracy of Class 1 refers to -40 to +1000 °C (Type K), Class 2 to -40 to +1200 °C (Type K), Class 3 to -200 to +40 °C (Type K).

\*\*According to standard 60751, the accuracies of Class A and B refer to -200 to +600 °C (Pt100)

**testo 735**
**Probes / Accessories**

Food probes	Illustration	Meas. range	Accuracy	t <sub>99</sub>	Part no.
<ul style="list-style-type: none"> <li>Robust food penetration probe with special handle, reinforced cable (PVC), T/C Type T</li> </ul>	<p>115 mm Ø 5 mm 30 mm Ø 3.5 mm Conn.: Fixed cable</p>	-50 to +350 °C	±0.2 °C (-20 to +70 °C) Class 1 (remaining range)*	6 s	0603 2492
<ul style="list-style-type: none"> <li>Frozen food probe, corkscrew design, T/C Type T</li> </ul>	<p>110 mm Ø 8 mm 30 mm Ø 4 mm Conn.: Plug-in cable</p>	-50 to +350 °C	±0.2 °C (-20 to +70 °C) Class 1 (remaining range)*	8 s	0603 3292
<ul style="list-style-type: none"> <li>Stainless steel food probe (IP67) with PUR cable, T/C Type T</li> </ul>	<p>125 mm Ø 4 mm 30 mm Ø 3.2 mm Conn.: Fixed cable</p>	-50 to +350 °C	±0.2 °C (-20 to +70 °C) Class 1 (remaining range)*	7 s	0603 2192
Waterproof precision immersion/penetration probe without visible penetration hole, T/C Type T	<p>70 mm Ø 5 mm 15 mm Ø 1.5 mm Conn.: Fixed cable 1.2 m</p>	-50 to +350 °C	±0.2 °C (-20 to +70 °C) Class 1 (remaining range)*		0603 2693
<ul style="list-style-type: none"> <li>Stainless steel food probe (IP67), with Teflon cable to +250 °C, T/C Type T</li> </ul>	<p>125 mm Ø 4 mm 30 mm Ø 3.2 mm Conn.: Fixed cable</p>	-50 to +350 °C	±0.2 °C (-20 to +70 °C) Class 1 (remaining range)*	7 s	0603 3392
<ul style="list-style-type: none"> <li>Waterproof, super-quick needle probe for measurements without visible penetration hole, T/C Type T</li> </ul>	<p>150 mm Ø 1.4 mm 60 mm Ø 1.4 mm Conn.: Fixed cable</p>	-50 to +250 °C	±0.2 °C (-20 to +70 °C) Class 1 (remaining range)*	2 s	0628 0027
<ul style="list-style-type: none"> <li>Quick needle probe to monitor cooking in oven, T/C Type T</li> </ul>	<p>60 mm Ø 1.4 mm 60 mm Ø 1.4 mm Conn.: Fixed cable</p>	-50 to +250 °C	±0.2 °C (-20 to +70 °C) Class 1 (remaining range)*	2 s	0628 0030
Measurement tip with T/C adapter Type T, ideal for fast-action measurement on incoming goods	<p>Ø 1.5 mm 500 mm</p>	-50 to +350 °C	Class 1*	5 s	0628 0023
Flexible open probe, Tmax +250 °C, Teflon line	<p>2000 mm Ø 1.5 mm</p>	-50 to +250 °C	Class 1*		0603 0646
Waterproof standard immersion/penetration probe, T/C Type T	<p>112 mm Ø 5 mm 50 mm Ø 4 mm Conn.: Fixed cable</p>	-50 to +350 °C	±0.2 °C (-20 to +70 °C) Class 1 (remaining range)*	7 s	0603 1293

\* The measuring instrument inside TopSafe is waterproof with this probe.

\* According to standard EN 60584-2, the accuracy of Class 1 refers to -40 to +350 °C (Type T).

## See back flap for radio probes

Accessories	Part no.
<b>Accessories for measuring instrument</b>	
Plug-in mains adapter, 5 VDC 500 mA with European adapter, 100-250 VAC, 50-60 Hz	0554 0447
<b>Printer and Accessories</b>	
Testo printer with wireless infrared interface, 1 roll of thermal paper and 4 AA batteries	0554 0547
Spare thermal paper for printer (6 rolls), measurement data documentation legible for up to 10 years	0554 0568
Spare thermal paper for printer (6 rolls)	0554 0569
External fast charger for 1-4 AA rech. batteries, incl. 4 Ni-MH rech. batteries with individual cell charging and charge control display, incl. impulse trickle charging, integrated discharge function, with built-in international mains plug, 100-240 V, 300 mA, 50/60 Hz	0554 0610
<b>Transport and Protection</b>	
Service case for basic equipment of measuring instrument and probes, dimensions: 400 x 310 x 96 mm	0516 0035
Service case for measuring instrument, probes and accessories, dimensions 520 x 380 x 120 mm	0516 0735
<b>Other features</b>	
Handle for attachable measurement tips	0409 1092
Extension cable, 5m, for thermocouple probe Type K	0554 0592
Silicone heat paste (14g), Tmax = +260°C improves heat transfer in surface probes	0554 0004

Accessories	Part no.
<b>Calibration certificates</b>	
ISO calibration certificate/temperature, for air/immersion probes, calibration points -18°C; 0°C; +60°C	0520 0001
ISO calibration certificate/temperature, Meas. instr. with air/immersion probe; cal. points 0°C; +150°C; +300°C	0520 0021
ISO calibration certificate/temperature, meas. instr. with surface probe; calibration points +60°C; +120°C; +180°C	0520 0071
DKD calibration certificate/temperature, meas. instr. with air/immersion probe; calibration points -20°C; 0°C; +60°C	0520 0211
DKD calibration certificate/temperature, contact surface temperature probes; calibration points +100°C; +200°C; +300°C	0520 0271
4-point adjustment, incl. ISO calibration certificate, calibration points freely selectable for probe 0614 0235	0520 0142
4-point adjustment, incl. DKD calibration certificate, calibration points freely selectable for probe 0614 0235	0520 0241

Accessories for system adjustment for testo 735-2	Part no.
Software for adjustment testo 735-2 with user management, incl. USB data transfer cable	0554 0823

Calibration certificates incl. adjustment for testo 735-2	Part no.
2-point adjustment incl. ISO calibration certificate, calibration points freely selectable	0520 0178
4-point adjustment incl. ISO calibration certificate, calibration points freely selectable	0520 0142
2-point adjustment incl. DKD calibration certificate, calibration points freely selectable	0520 0278
4-point adjustment incl. DKD calibration certificate, calibration points freely selectable	0520 0241

## testo 950

## Highly accurate reference measuring instrument

Precision reference class measuring instruments have everything the professional user needs to complete complicated measurement tasks efficiently, accurately and conveniently.

testo 950 includes the basic parameters temperature, CO<sub>2</sub>, rpm, current and voltage. testo 950 can be upgraded to the multi-function measuring instrument, testo 400.

The measuring instrument can keep up with the measurement tasks at hand thanks to upgrades. Intelligent electronics ensure the latest technology is used thanks to software updates.

Upgradable and teachable, highly reliable and of the highest quality - they are the properties which guarantee that the customer is equipped for the future.

**NEW: Incl Mass memory up to 500,000 readings!**



Attachable printer  
Readings are printed on site in seconds

Clear graphics display

Data communication with PC  
Barcode reader

3 user defined function buttons

Saves (max. 500,000 readings) or prints at the touch of a button

User-friendly operation with cursor

Mains connection/quick battery recharging  
2 user defined probe sockets, automatic recognition of all connected probes

testo 950, reference temperature meas. instr., with battery, Li cell and calibration protocol

Part no.  
**0563 9501**

### Recommended set

#### Precision measuring instrument with up to 0.05 °C system accuracy

- testo 950, reference temperature meas. instr., with battery, Li cell and calibration protocol, 2 channel instrument (thermocouple, Pt100, NTC) with option of connecting CO, CO<sub>2</sub>, rpm and mV/mA transmitter (Part no. 0563 9501)
- Highly accurate immersion/penetration probe incl. certificate, plug-in head, connection cable 0430 0143 or 0430 0145 required (Part no. 0614 0240)
- Cable, 1.5 m long, connects probe with plug-in head to meas. instrument, PUR coating material (Part no. 0430 0143)
- Attachable printer (securely attached) including 1 roll of thermal paper and batteries, quickly prints readings on location (Part no. 0554 0570)
- System case (plastic) for measuring instrument, probes and accessories, probes in lid make it easy to find parts in case (540 x 440 x 130 mm) (Part no. 0516 0400)

#### We recommend:

4-point adjustment for probe 0614 0240, incl. ISO certificate at -40, 0, +100, +300 °C 0520 0142

4-point adjustment, incl. DKD calibration certificate, calibration points freely selectable 0520 0241

ComSoft 3 - Professional with data management, incl. database, analysis and graphics function, data analysis, trend curve 0554 0830

RS232 cable, connects instrument to PC (1.8 m) for data transfer 0409 0178

### Recommended set

#### Data management

- ComSoft 3 - Professional with data management, incl. database, analysis and graphics function, data analysis, trend curve (Part no. 0554 0830)
- RS232 cable, connects instrument to PC (1.8 m) for data transfer (Part no. 0409 0178)
- Barcode reader to read in measurement locations, quick and accurate allocation of reading to site (Part no. 0554 0460)



**testo 950**
**Suitable probes at a glance**

Probes Type K (NiCr-Ni)	Illustration	Meas. range	Accuracy	t99	Part no.
Thermocouple, made of fibre-glass insulated thermal pipes, pack of 5	<p>Please order adapter 0600 1693</p>	-200 to +400 °C	Class 1**	5 s	0644 1109
Quick-action surface probe with sprung thermocouple strip, measuring range short-term to +500°C	<p>Conn.: Plug-in head, connection cable 0430 0143 or 0430 0145 required</p>	-200 to +300 °C	Class 2**	3 s	0604 0194
Super quick-action surface probe, probe tip at 90° angle, with sprung thermocouple strip	<p>Conn.: Plug-in head, connection cable 0430 0143 or 0430 0145 required</p>	-200 to +300 °C	Class 2**	3 s	0604 0994
Robust surface probe with sprung thermocouple strip for high temperature range up to +700°C	<p>Conn.: Fixed cable, coiled</p>	-200 to +700 °C	Class 2**	3 s	0600 0394
Roller surface probe for measurements on rollers and rotating drums, max. circumferential velocity 18 to 400m/min	<p>Conn.: Fixed cable, coiled</p>	-50 to +240 °C	Class 2**		0600 5093
Magnetic probe, adhesive power approx. 20 N, with magnets, for measurements on metal surfaces	<p>Conn.: Fixed cable</p>	-50 to +170 °C	Class 2**	150 s	0600 4793
Magnetic probe, adhesive power approx. 10 N, with magnets, for higher temperatures, measures on metal surfaces	<p>Conn.: Fixed cable</p>	-50 to +400 °C	Class 2**		0600 4893
Adhesive thermocouple, pack of 2, carrier material: aluminium foil	<p>Diameter extension 2 x 0.2 mm, 0.1 mm thick</p>	-200 to +200 °C	Class 1**		0644 1607
Is fixed at the measuring point using conventional adhesives or silicone heat paste 0554 0004					
Fast response immersion/penetration probe	<p>Conn.: Plug-in head, connection cable 0430 0143 or 0430 0145 required</p>	-200 to +400 °C	Class 1**	3 s	0604 0293
Super quick-action immersion/penetration probe for measurements in liquids	<p>Conn.: Plug-in head, connection cable 0430 0143 or 0430 0145 required</p>	-200 to +600 °C	Class 1**	1 s	0604 0493
Super quick-action immersion/penetration probe for high temperatures	<p>Conn.: Plug-in head, connection cable 0430 0143 or 0430 0145 required</p>	-200 to +1100 °C	Class 1**	1 s	0604 0593
Robust immersion/penetration probe made of V4A stainless steel, waterproof and oven-proof, e.g. for the food sector	<p>Conn.: Fixed cable</p>	-200 to +400 °C	Class 1**	3 s	0600 2593
Smelting probe for measurements in non-ferrous melting baths, with exchangeable measuring tip	<p>Conn.: Fixed cable</p>	-200 to +1250 °C	Class 1**	60 s	0600 5993
Pipe wrap probe for pipes with diameter of up to 2", for flow/return temp. meas. in hydronic systems	<p>Conn.: Fixed cable</p>	-60 to +130 °C	Class 2**	5 s	0600 4593
Spare meas. head for pipe wrap probe, TC Type K		-60 to +130 °C	Class 2**	5 s	0602 0092

\*with EEPROM: Precision adjustment for each probe at a measuring point; measuring range limits are saved in probe; t95 extrapolation; surface allowance in surface probe can be adapted to measuring task

\*\*According to standard EN 60584-2, the accuracy of Class 1 refers to -40 to +1000 °C (Type K), Class 2 to -40 to +1200 °C (Type K), Class 3 to -200 to +40 °C (Type K).

Probes Type K (NiCr-Ni)	Illustration	Meas. range	Accuracy	t99	Part no.
Plug-in measuring tip, 750mm long, flexible, for high temperatures, outer casing: stainless steel 1.4541	750 mm Ø 3 mm Please order handle with Part no. 0600 5593	-200 to +900 °C	Class 1**	4 s	0600 5393
Plug-in measuring tip, 550mm long, flexible, for high temperatures, outer casing: Inconel 2.4816	550 mm Ø 3 mm Please order handle with Part no. 0600 5593	-200 to +1100 °C	Class 1**	4 s	0600 5793
Plug-in measuring tip, 1030mm long, flexible, for high temperatures, outer casing: Inconel 2.4816	1030 mm Ø 3 mm Please order handle with Part no. 0600 5593	-200 to +1100 °C	Class 1**	4 s	0600 5893

Probes Pt100	Illustration	Meas. range	Accuracy	t99	Part no.
Standard air probe	150 mm Ø 3 mm Conn.: Plug-in head, connection cable 0430 0143 or 0430 0145 required	-200... +600 °C	Class A***	75 s	0604 9773
Precision air probe	150 mm Ø 3 mm Conn.: Plug-in head, connection cable 0430 0143 or 0430 0145 required	-100 to +400 °C	1/10 Class B (0 to 100°C) 1/5 Class B (rem. range) to EN 60751***	75 s	0628 0017
Robust surface probe	150 mm Ø 4 mm Conn.: Plug-in head, connection cable 0430 0143 or 0430 0145 required	-50 to +400 °C	Class B***	40 s	0604 9973
Velcro probe for pipes with diameter of max. 75 mm	280 mm Conn.: Fixed cable	-50 to +150 °C	Class B***	40 s	0628 0019
Standard immersion/penetration probe	200 mm Ø 3 mm Conn.: Plug-in head, connection cable 0430 0143 or 0430 0145 required	Stainless Steel -200 to +400 °C	Class A***	20 s	0604 0273
Standard immersion/penetration probe	200 mm Ø 3 mm Conn.: Plug-in head, connection cable 0430 0143 or 0430 0145 required	Nickel -200 to +600 °C	Class A***	20 s	0604 0274
Highly accurate immersion/penetration probe incl. certificate	295 mm Ø 4 mm Conn.: Plug-in head, connection cable 0430 0143 or 0430 0145 required	Stainless Steel -40 to +300 °C	±0.05 °C (+0.01 to +100 °C) ±(0.05 °C ±0.05% of mv) (-40 to 0 °C) ±(0.05 °C ±0.05% of mv) (+100.01 to +300 °C)	60 s	0614 0240
Highly accurate immersion/penetration probe	200 mm Ø 3 mm Conn.: Plug-in head, connection cable 0430 0143 or 0430 0145 required	-100 to +400 °C	1/10 Class B (0 to 100°C) 1/5 Class B (rem. range) to EN 60751***	30 s	0628 0015
Flexible precision immersion probe, cable heat-proof up to +300°C	1000 mm Ø 3.5 mm Conn.: Plug-in head, connection cable 0430 0143 or 0430 0145 required	50 mm Ø 6 mm -100 to +265 °C	1/10 Class B (0 to 100°C) 1/5 Class B (rem. range) to EN 60751***	80 s	0628 0016
Robust immersion/penetration probe with sharpened measuring tip, waterproof and oven-proof	150 mm Ø 3.5 mm Conn.: Fixed cable	Ø 3 mm -200 to +400 °C	Class A***	30 s	0604 2573





Probes NTC	Illustration	Meas. range	Accuracy	t99	Part no.
Highly accurate air probe for air and gas temperature measurements with bare, mechanically protected sensor	150 mm Ø 9 mm Conn.: Fixed cable	-40 to +130 °C	To UNI curve	60 s	0610 9714
Globe thermometer to measure radiant heat	Ø 150 mm Conn.: Fixed cable	0 to +120 °C	±0.5 °C (0 to +49.9 °C) ±1 °C (+50 to +120 °C) Accuracy corresponds to ISO 7243, ISO 7726, DIN EN 27726, DIN 33403 requirements		0554 0670

\*with EEPROM: Precision adjustment for each probe at a measuring point; measuring range limits are saved in probe; t95 extrapolation; surface allowance in surface probe can be adapted to measuring task

\*\* According to standard EN 60584-2, the accuracy of Class 1 refers to -40 to +1000 °C (Type K), Class 2 to -40 to +1200 °C (Type K), Class 3 to -200 to +40 °C (Type K).

\*\*\* According to standard 60751, the accuracies of Class A and B refer to -200 to +600 °C (Pt100)

**testo 950**
**More probes / Accessories**

More probes	Illustration	Meas. range	Accuracy	Part no.
Ambient CO probe, for detecting CO in buildings and rooms	 Conn.: Fixed cable, 1.5 m	0 to +500 ppm CO	±5% of mv (+100.1 to +500 ppm CO) ±5 ppm CO (0 to +100 ppm CO)	0632 3331
CO <sub>2</sub> probe measures indoor air quality and monitors the workplace. With plug-in head, connection cable 0430 0143 or 0430 0145 required	 Conn.: Plug-in head, connection cable 0430 0143 or 0430 0145 required	0...+1 Vol. % CO <sub>2</sub> 0...+10000 ppm CO <sub>2</sub>	±(50 ppm CO <sub>2</sub> ±2% of mv)(0 to +5000 ppm CO <sub>2</sub> ) ±(100 ppm CO <sub>2</sub> ±3% of mv)(+5001 to +10000 ppm CO <sub>2</sub> )	0632 1240
Mechanical rpm probe with plug-in head  Included 2 probe tips Ø 8 and Ø 12 mm 1 hollow cone Ø 8 mm 1 surface speed disc Ø 19 mm to measure rotational speed: rpm = rotational speed in mm/s	 Conn.: Plug-in head, connection cable 0430 0143 or 0430 0145 required	20 to 20000 rpm	±1 digit	0640 0340
Current/voltage cable (±1 V, ±10 V, 20 mA)		0 to +1000 mV 0 to +10 V 0 to +20 mA	±1 mV (0 to +1000 mV) ±0.01 V (0 to +10 V) ±0.04 mA (0 to +20 mA)	0554 0007
4 to 20 mA interface for connection and intermittent power supply to transmitters (scaling via hand-held instrument), in robust metal housing with impact protection, incl. magnet for fast attachment	 Channels 1 Auxiliary energy output 18V DC ± 20% max. connection load 30 mA Conn.: Plug-in head, connection cable 0430 0143 or 0430 0145 required	0/4 to 20 mA	±0.04 mA	0554 0528

**Accessories Probes**
**Part no.**

Cable, 1.5 m long, connects probe with plug-in head to meas. instrument, PUR coating material	0430 0143
Cable, 5 m long, connects probe with plug-in head to measuring instrument, PUR coating material	0430 0145
Extension cable, 5 m long, between plug-in head cable and instrument, PUR coating material	0409 0063
Telescopic handle, max. 1 m, for probe with plug-in head, cable: 2.5 m long, PUR coating material	0430 0144
Adapter to connect NiCr-Ni thermocouples and probes with open wire ends	0600 1693
Handle for plug-in measuring tip	0600 5593
Silicone heat paste (14g), Tmax = +260°C, improves heat transfer in surface probes	0554 0004
Spare measuring tip for smelting probe	0363 1712

Accessories	Part no.
<b>Transport and Protection</b>	
SoftCase (protects instrument from impact) with carrier strap, magnetic holder and probe holder, protects against impact and falls	0516 0401
SoftCase for attachable printer (protects printer from dirt/impact), protects from impact and falls	0516 0411
System case (plastic) for measuring instrument, probes and accessories, probes in lid make it easy to find parts in case (540 x 440 x 130 mm)	0516 0400
System case (aluminium) for measuring instrument, probes and accessories, probes in lid make it easy to find parts in case	0516 0410
<b>Printer and accessories</b>	
Attachable printer (securely attached) including 1 roll of thermal paper and batteries, quickly prints readings on location	0554 0570
Testo printer with wireless infrared interface, 1 roll of thermal paper and 4 AA batteries	0554 0547
Fast testo 575 printer, incl. 1 roll of thermal paper and batteries, infrared thermal line printer with graphics function	0554 1775
External fast charger for 1-4 AA rech. batteries, incl. 4 Ni-MH rech. batteries with individual cell charging and charge control display, incl. impulse trickle charging, integrated discharge function, with built-in international mains plug, 100-240 V, 300 mA, 50/60 Hz	0554 0610
Spare thermal paper for printer (6 rolls)	0554 0569
Spare thermal paper for printer (6 rolls), measurement data documentation legible for up to 10 years	0554 0568
Label thermal paper (Testo patent) for testo 575 printer (6 rolls), can be applied directly	0554 0561
<b>Additional accessories and spare parts</b>	
Rech. batt. set for instr. (2 rech. 2.4V/1100mAh)	0554 0196
Car charging adapter, ready to measure following recharging in car, battery is recharged while travelling in car	0554 0424
Lithium battery, button cell, type CR 2032, Spare Li cell to save RAM data, when changing battery and rech. battery	0515 0028
<b>Update</b>	
Humidity/pressure module , Upgrade via service (updates testo 950 to testo 650)	0450 4002
Velocity module, incl. volume flow, degree of turbulence... , upgrade via service (updates testo 650 to testo 400)	0450 4003
<b>Barcode and Accessories</b>	
Barcode reader to read in measurement locations, quick and accurate allocation of reading to site	0554 0460
Adhesive pockets (50 off) for printout, paper barcode labels...	0554 0116
<b>Software and accessories</b>	
ComSoft 3 - Professional with data management, incl. database, analysis and graphics function, data analysis, trend curve	0554 0830
RS232 cable, connects instrument to PC (1.8 m) for data transfer	0409 0178
Ethernet adapter, RS232 - Ethernet incl. software driver, mains unit, facilitates data communication in network	0554 1711

Accessories	Part no.
<b>Calibration certificates</b>	
ISO calibration certificate/temperature, for air/immersion probes, calibration points -18°C; 0°C; +60°C	0520 0001
ISO calibration certificate/temperature, Meas. instr. with air/immersion probe; cal. points 0°C; +150°C; +300°C	0520 0021
ISO calibration certificate/temperature, meas. instr. with surface probe; calibration points +60°C; +120°C; +180°C	0520 0071
4-point adjustment , incl. ISO calibration certificate , calibration points freely selectable for probe 0614 0240	0520 0142
4-point adjustment , incl. DKD calibration certificate, calibration points freely selectable for probe 0614 0240	0520 0241
DKD calibration certificate/temperature, meas. instr. with air/immersion probe; calibration points -20°C; 0°C; +60°C	0520 0211
DKD calibration certificate/temperature, contact surface temperature probes; calibration points +100°C; +200°C; +300°C	0520 0271
<b>ISO/DKD calibration certificates for testo 950 are possible at user defined points within the measuring range.</b>	

**testo 950**
**Technical data**

Technical data			
Probe type	Pt100	Pt100 with probe 0614 0240	NTC
Meas. range	-200 to +800 °C	-40 to +300 °C	-40 to +150 °C
Accuracy ±1 digit	±0.1 °C (-49.9 to +99.9 °C) ±(0.1 °C + 0.1% of mv) remaining range	See probe data	±0.2 °C (-10 to +50 °C) ±0.4 °C (-40 to -10.1 °C) ±0.4 °C (+50.1 to +150 °C)
Resolution	0.01 °C (-99.9 to +300 °C) 0.1 °C (-200 to -100 °C) 0.1 °C (+300.1 to +800 °C)	Display 0.001 °C (-40.000 to +300.000 °C) Instrument store 0.01 °C ComSoft 3 0.01 °C	0.1 °C

Probe type	Type K (NiCr-Ni)	Type S (Pt10Rh-Pt)	Type J (Fe-CuNi)
Meas. range	-200 to +1370 °C	0 to +1760 °C	-200 to +1000 °C
Accuracy ±1 digit	±(0.3 °C + 0.1% of mv)	±1 °C	±0.4 °C (-150 to +150 °C) ±1 °C (-200 to -150.1 °C) ±1 °C (+150.1 to +1000 °C)
Resolution	0.1 °C (-200 to +1370 °C)	1 °C	0.1 °C

Probe type	CO2 probe	CO probe	Mechanical
Meas. range	0 to +1 Vol. % CO <sub>2</sub> 0 to +10000 ppm CO <sub>2</sub>	0 to +500 ppm CO	20 to 20000 rpm
Accuracy ±1 digit	See probe data	±5% of mv (0 to +500 ppm CO)	±1 digit
Resolution			1 rpm

Probe type	Current measurement	Voltage measurement
Meas. range	0 to +20 mA	0 to +10 V
Accuracy ±1 digit	±0.04 mA	±0.01 V
Resolution	0.01 mA	0.01 V

Oper. temp.	0 to +50 °C	Memory space: 1 MB, corresponds to approx. 500,000 readings Other features: automatic recognition of all connected probes Power supply: Battery/rech. batt., alternatively 8V mains unit Battery life in continuous operation with 2 TC probes: 18 h
Storage temp.	-25 to +60 °C	
Display	LCD, 4 lines	
Battery type	1,5 V AA	
Battery life	18 h	
Weight	500 g	
PC	RS232 interface	
Material/Housing	ABS	
Warranty	3 years	



**testo 810**
**Air temperature and infrared surface temperature in one instrument**

testo 810 allows the measurement of air temperature and simultaneous non-contact surface temperature measurement in one instrument

**testo 810; 2-channel temperature measuring instrument with infrared thermometer with laser spot marking and integrated NTC air thermometer, incl. protective cap, batteries and calibration protocol**

Part no.

**0560 0810**

- Infrared measurement with 1-point laser spot marking and 6:1 optics
- Display of difference between air and surface temperature
- Hold function and min./max. values
- Emissivity adjustable
- Display illumination
- Protective cap for safe storage
- Incl. wrist strap and belt holder
- Incl. calibration protocol

**Technical data**

Probe type	Infrared	NTC
Meas. range	-30 to +300 °C	-10 to +50 °C
Accuracy	±2.0 °C (-30 to +100 °C) ±1 digit ±2% of mv (remaining range)	±0.5 °C
Measurement rate	0.5 s	0.5 s
Resolution	0.1 °C	0.1 °C
Distance to measurement spot	6:1	
Meas. spot marking	1-point laser	
Emissivity	Adjustable 0.2 to 0.99	
Spectral range	8 to 14 µm	
		Oper. temp. -10 to +50 °C
		Battery type 2 batteries Type AAA
		Battery life 50 h (average, without display illumination)
		Dimensions 119 x 46 x 25 mm (incl. protective cap)
		Weight 90 g (incl. battery and protective cap)

**Accessories**

	Part no.
Adhesive tape e.g. for polished surfaces (roll, 10 m long, 25 mm wide), E = 0.95, temperature resistant up to +300°C	0554 0051
ISO calibration certificate/temperature, Infrared thermometers, calibration points -18°C, 0°C, +60°C	0520 0401
ISO calibration certificate/temperature, infrared thermometer; calibration points +60°C; +120°C; +180°C	0520 0002
ISO calibration certificate/temperature; for air/immersion probes, calibration points -8°C; 0°C; +40°C	0520 0181

**testo 830-T1**
**Fast infrared thermometer with laser sighting (10:1 optics)**

The fast and universal infrared thermometer with 1-point laser sighting and 10:1 optics in ergonomic "pistol design"

**testo 830-T1, Infrared thermometer with 1 point laser sighting, adjustable limit values and alarm function**

Part no.

**0560 8301**

- Display of current value and Hold value
- Fast readings
- Laser sighting
- Adjustable alarm limits
- Audible and visual alarm if limits are exceeded
- User-friendly thanks to "Pistol design"
- Backlit display
- Adjustable emission factor (0.2 to 1.0)

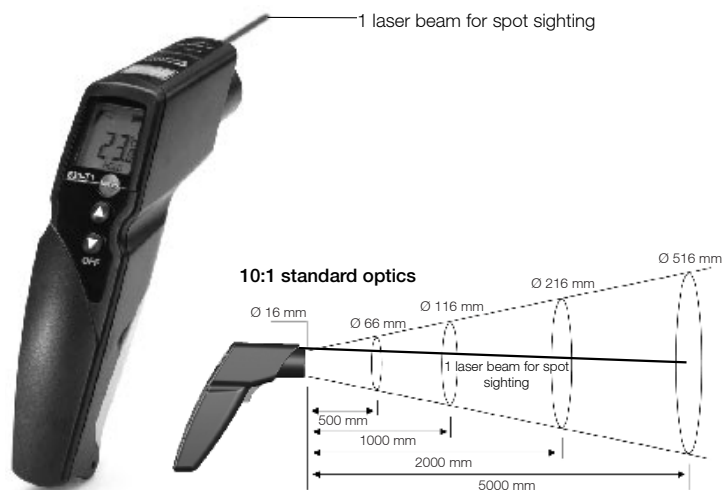
**Technical data**

Probe type	Infrared	
Spectral range	8 to 14 µm	Distance to measurement spot 10:1
Meas. range	-30 to +400 °C	Meas. spot marking 1-point laser
Accuracy	±1.5 °C or 1.5 % of mv (+0.1 to +400 °C) ±2 °C or ±2 % of mv (-30 to 0 °C) The larger value applies	Emissivity Adjustable 0.2 to 1.0
±1 digit		Oper. temp. -20 to +50 °C
		Storage temp. -40 to +70 °C
		Battery type 9V block battery
		Battery life 15 h
		Material/Housing ABS
Measurement rate	0.5 s	Dimensions 190 x 75 x 38 mm
Resolution	0.5 °C	Weight 200 g

**Accessories**

	Part no.
Adhesive tape e.g. for polished surfaces (roll, 10 m long, 25 mm wide), E = 0.95, temperature resistant up to +300°C	0554 0051
Leather case to protect measuring instrument, including belt holder	0516 8302
ISO calibration certificate/temperature, infrared thermometer; calibration points +60°C; +120°C; +180°C	0520 0002

## testo 830-T2

## Infrared thermometer with 2-point laser sighting and probe socket (12:1 optics)

The fast and versatile infrared thermometer with 2-point laser marking and 12:1 optics. Possibility of connecting an external Type K probe for contact measurement.

**In addition to the benefits of testo 830-T1:**

- 2-point laser sighting
- Contact measurement with connectable temperature probe
- Emissivity determination with external TC probe

**testo 830-T2, Infrared thermometer with 2-point laser sighting, adjustable limit values, alarm function and connection of external probes**

Part no.  
**0560 8302**

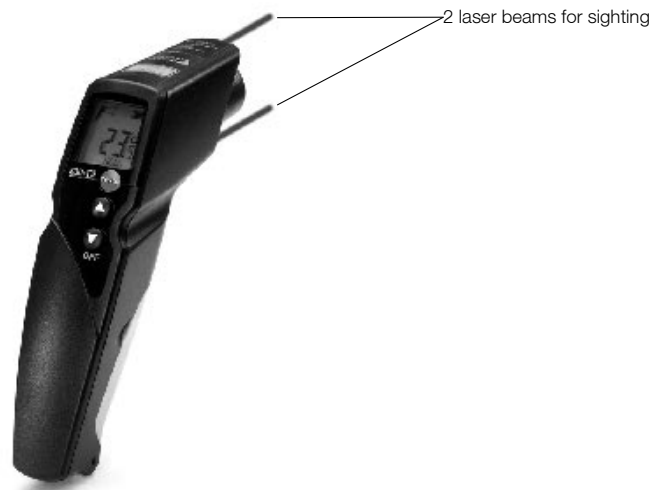

**Fast measurement value recording at 2 measurements per second**

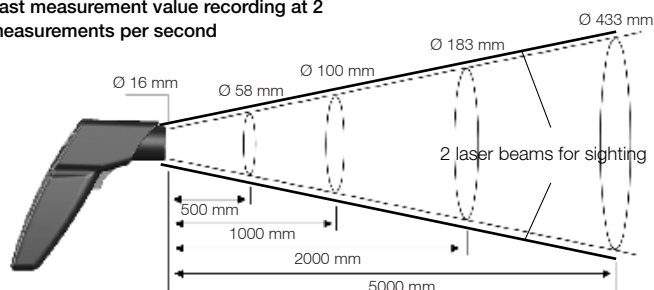

Set	Part no.
<b>testo 830-T2 Set</b>	0563 8302
- testo 830-T2, Infrared thermometer with 2-point laser sighting, adjustable limit values, alarm function and connection of external probes - Fast-action surface probe with sprung thermocouple strip, also for uneven surfaces, measurement range short-term to +500°C, TC Type K - Leather case to protect measuring instrument, including belt holder	

Technical data		
Probe type	Infrared	Type K (NiCr-Ni)
Spectral range	8 to 14 $\mu\text{m}$	
Meas. range	-30 to +400 °C	-50 to +500 °C
Accuracy $\pm 1$ digit	$\pm 1.5$ °C or $\pm 1.5\%$ of mv (+0.1 to +400 °C) $\pm 2$ °C or $\pm 2\%$ of mv (-30 to 0 °C) The larger value applies	$\pm 0.5$ °C +0.5% of mv
Resolution	0.5 °C	0.1 °C
Measurement rate	0.5 s	1.75 s
Meas. spot marking	2-point laser	
Emissivity	Settable 0.2 to 1.0	
Distance to measurement spot	12:1	

Accessories	Part no.
Adhesive tape e.g. for polished surfaces (roll, 10 m long, 25 mm wide), E = 0.95, temperature resistant up to +300°C	0554 0051
Leather case to protect measuring instrument, including belt holder	0516 8302
ISO calibration certificate/temperature, infrared thermometer; calibration points +60°C; +120°C; +180°C	0520 0002
ISO calibration certificate/temperature, for air/immersion probes, calibration point +60°C	0520 0063
ISO calibration certificate/temperature, for air/immersion probes, calibration points -18°C; 0°C; +60°C	0520 0001
ISO calibration certificate/temperature, meas. instr. with surface probe; calibration points +60°C; +120°C; +180°C	0520 0071
ISO calibration certificate/temperature, Meas. instr. with air/immersion probe; cal. points 0°C; +150°C; +300°C (Applies only to immersion/penetration probe 0602 2693)	0520 0021

Oper. temp.	-20 to +50 °C	Battery life	15 h
Storage temp.	-40 to +70 °C	Dimensions	190 x 75 x 38 mm
Battery type	9V block battery	Weight	200 g

Air probes	Illustration	Meas. range	Accuracy	t99	Part no.
Robust air probe, T/C Type K	Conn.: Fixed cable 1.2 m	-60 to +400 °C	Class 2*	25 s	0602 1793
Immersion/penetr. probes	Illustration	Meas. range	Accuracy	t99	Part no.
Waterproof immersion/penetration probe, TC Type K	Conn.: Fixed cable 1.2 m	-60 to +400 °C	Class 2*	7 s	0602 1293
Surface probes	Illustration	Meas. range	Accuracy	t99	Part no.
Fast-action surface probe with sprung thermocouple strip, also for uneven surfaces, measurement range short-term to +500°C, TC Type K	Conn.: Fixed cable 1.2 m	-60 to +300 °C	Class 2*	3 s	0602 0393

\*According to standard 60584-2, the accuracy of Class 2 refers to -40 to +1200 °C (Type K).

**Further probes see page 44/45**



**testo 830-T4**

The fast and versatile infrared thermometer with 2-point laser marking and 30:1 optics. The surface temperature, also of smaller objects, can be measured at a safe distance. The diameter of the measurement spot is only 36 mm at a distance of 1 m. Possibility of connecting external temperature probes.

**Infrared thermometer with 2-point laser marking and probe socket (30:1 optics)**

- Display of current value and Hold value
- 30:1 optics for measuring temperature at a distance, even on small objects
- 2 laser beams for marking the measurement spot
- °C contact measurement with connectable TC probe
- Emissivity determination with external temperature probe
- Fast measurement value recording at two measurements per second
- Input of upper and lower limit value
- Audible and optical alarm when limit values are exceeded
- Display illumination



IR temperature measuring instrument with 30:1 optics and 2-point laser measurement spot sighting, incl. battery and factory calibration certificate with the meas. points +80 °C and +350 °C

Part no.  
**0560 8304**

**Set testo 830-T4**

testo 830-T4 set, consisting of testo 830-T4 with protective leather case, incl. cross-band surface probe, battery and factory calibration certificate with the measurement points +80 °C and +350 °C

Part no.  
**0563 8304**

Distance to measurement spot 30:1

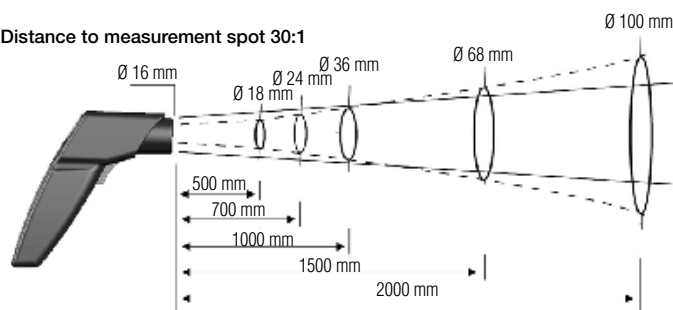

Technical data		
Probe type	Infrared	Type K (NiCr-Ni)
Spectral range	8 to 14 µm	
Meas. range	-30 to +400 °C	-50 to +500 °C
Accuracy ±1 digit	±1,5 °C (-20 to 0 °C) ±2 °C (-30 to -20,1 °C) ±1 °C or 1% of mv (remaining range)	±0,5 °C +0,5% of mv
Resolution	0,1 °C	0,1 °C
Measurement rate	0,5 s	1,75 s
Meas. spot marking	2-point laser	
Emissivity	Settable 0.2 to 1.0	
Distance to measurement spot	30:1 (typical at a distance of 0.7 m to the measurement object 24 mm @ 700 mm (90%))	

Oper. temp.	-20 to +50 °C
Storage temp.	-40 to +70 °C
Battery type	9V block battery
Battery life	15 h

Material/Housing	ABS
Dimensions	190 x 75 x 38 mm
Weight	200 g

Accessories	Part no.
Adhesive tape e.g. for polished surfaces (roll, 10 m long, 25 mm wide), E = 0.95, temperature resistant up to +300°C	0554 0051
Leather case to protect measuring instrument, including belt holder	0516 8302
ISO calibration certificate/temperature, infrared thermometer; calibration points +60°C; +120°C; +180°C	0520 0002
ISO calibration certificate/temperature, meas. instr. with surface probe; calibration points +60°C; +120°C; +180°C	0520 0071
ISO calibration certificate/temperature, for air/immersion probes, calibration point +60°C	0520 0063
ISO calibration certificate/temperature, for air/immersion probes, calibration points -18°C; 0°C; +60°C	0520 0001
ISO calibration certificate/temperature, Meas. instr. with air/immersion probe; cal. points 0°C; +150°C; +300°C (Applies only to immersion/penetration probe 0602 2693)	0520 0021

Surface probes	Illustration	Meas. range	Accuracy	t99	Part no.
Fast-action surface probe with sprung thermocouple strip, also for uneven surfaces, measurement range short-term to +500°C, TC Type K	<p>Conn.: Fixed cable 1.2 m</p>	-60 to +300 °C	Class 2*	3 s	0602 0393

\*According to standard 60584-2, the accuracy of Class 2 refers to -40 to +1200 °C (Type K).

Probes see page 44/45

## testo 830-T3

The fast infrared thermometer testo 830-T3 is especially suited to temperature measurements on surfaces with a small diameter. A two-point laser marks the measurement point exactly.

IR temperature measuring instrument with close focus optics, incl. 2 point laser sighting, adjustable limit values and alarm function, contact temperature probe attachable, incl. battery

Part no.  
**0560 8303**

## Non-contact temperature measurement with close focus optics (2.5:1 optics)

- Small measurement point of 2 mm, distance 25 mm
- °C contact measurement with attachable TC probe
- Backlit display
- Audible and optical alarm when limit values are exceeded
- Emissivity adjustable 0.2 to 1.0

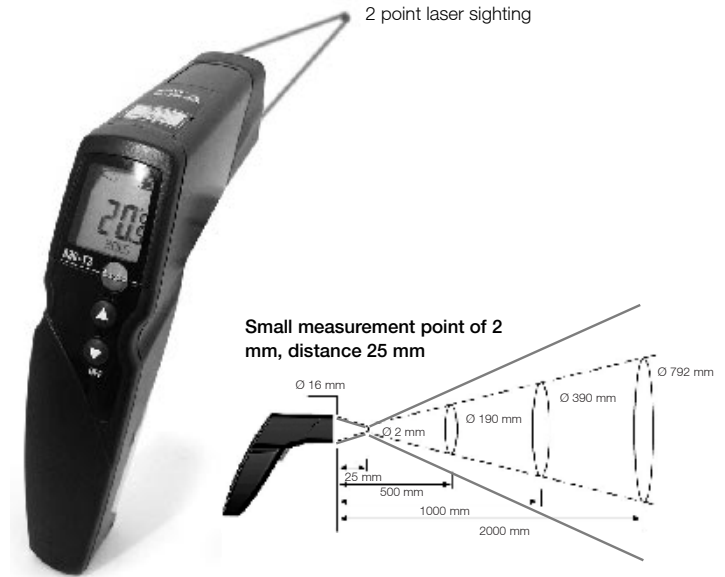

Technical data		
Probe type	Infrared	Type K (NiCr-Ni)
Spectral range	8 to 14 $\mu\text{m}$	
Meas. range	-25 to +400 °C	-50 to +500 °C
Accuracy $\pm 1$ digit	$\pm 1$ °C (-20 to +100 °C) $\pm 2$ °C or $\pm 2\%$ of mv (remaining range)	$\pm 0.5$ °C +0.5% of mv
Resolution	0.5 °C	0.1 °C
Measurement rate	0.5 s	1,75 s
Distance to measurement spot	2.5:1 2 mm @ 25 mm (90%)	
Meas. spot marking	2-point laser	
Emissivity	Settable 0.2 to 1.0	
Oper. temp.	-20 to +50 °C	Dimensions 155 x 136 x 38 mm
Storage temp.	-40 to +70 °C	Weight 200 g
Battery type	9V block battery	Warranty 2 years
Battery life	15 h	

Accessories	Part no.
Adhesive tape e.g. for polished surfaces (roll, 10 m long, 25 mm wide), E = 0.95, temperature resistant up to +300°C	0554 0051
Leather case to protect measuring instrument, including belt holder	0516 8302
ISO calibration certificate/temperature, infrared thermometer; calibration points +60°C; +120°C; +180°C	0520 0002
ISO calibration certificate/temperature, for air/immersion probes, calibration point +60°C	0520 0063
ISO calibration certificate/temperature, for air/immersion probes, calibration points -18°C; 0°C; +60°C	0520 0001
ISO calibration certificate/temperature, meas. instr. with surface probe; calibration points +60°C; +120°C; +180°C	0520 0071
ISO calibration certificate/temperature, Meas. instr. with air/immersion probe; cal. points 0°C; +150°C; +300°C (Applies only to immersion/penetration probe 0602 2693)	0520 0021

Air probes	Illustration	Meas. range	Accuracy	t99	Part no.
Robust air probe, T/C Type K		-60 to +400 °C	Class 2*	25 s	0602 1793
Immersion/penetr. probes	Illustration	Meas. range	Accuracy	t99	Part no.
Waterproof immersion/penetration probe, TC Type K		-60 to +400 °C	Class 2*	7 s	0602 1293
Surface probes	Illustration	Meas. range	Accuracy	t99	Part no.
Fast-action surface probe with sprung thermocouple strip, also for uneven surfaces, measurement range short-term to +500°C, TC Type K		-60 to +300 °C	Class 2*	3 s	0602 0393

\*According to standard 60584-2, the accuracy of Class 2 refers to -40 to +1200 °C (Type K).

Further probes see page 44/45

**testo 845**
**Infrared Thermometer with Switchable Optics (far-field/close focus)**

For the first time, surface temperatures with smallest diameters can be measured accurately at short and long distances. The switchable optics for far-field and close focus measurement make this possible. Measurements in the far-field are made with an optical resolution of 75:1. Surface temperatures can thus be measured accurately even at greater distances from the object to be measured. At a distance of 1.2 metres from the object, the measurement point diameter is only 16 mm. A cross laser marks the measurement point exactly.

For measurements at a small distance from the object to be measured, the close focus optics provide a measurement point diameter of only 1 mm at a distance of 70 mm! Two laser points mark the measurement point.

- Switchable optics for far-field measurements (75:1) and close focus (1 mm, 70 mm distance)
- Especially bright cross laser sighting for indicating the actual measuring point
- Reference accuracy  $\pm 0.75\text{ }^{\circ}\text{C}$  with super-fast measurement technology (scanning 100 ms)
- Backlit display (3-line) showing  $^{\circ}\text{C}$ , min./max. values, alarm limit values and degree of emission
- Optical and audible alarm when limit values are exceeded
- Probe socket for TC probes for determining emissivity
- Instrument memory for 90 measurement protocols
- PC software for archiving and documenting measurement data (included in delivery)
- Tripod fitting for online measurement via USB cable (included in delivery)
- Measurement data documentation on site with testo report printer
- Aluminium case for instrument and accessories (included)

**testo 845, infrared temperature measuring instrument with cross laser marking and switchable optics for far-field and close focus measurement, incl. PC software with USB data transfer cable, aluminium case, battery and calibration protocol**

Part no.  
**0563 8450**

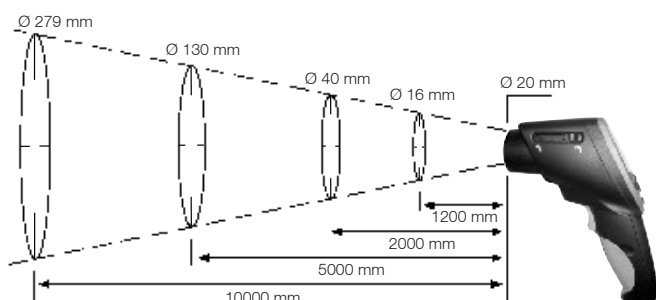
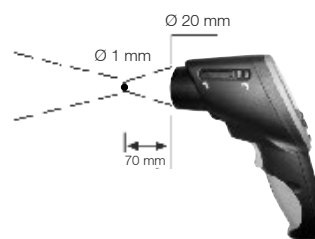
**Far-field measurement**

**Close focus measurement**

Switch to far-field measurement at a measurement distance > 250 mm.

Technical data		
Probe type	Infrared	Type K (NiCr-Ni)
Meas. range	-35 to +950 $^{\circ}\text{C}$	-35 to +950 $^{\circ}\text{C}$
Spectral range	8 to 14 $\mu\text{m}$	
Accuracy $\pm 1$ digit	$\pm 2.5\text{ }^{\circ}\text{C}$ (-35 to -20.1 $^{\circ}\text{C}$ ) $\pm 1.5\text{ }^{\circ}\text{C}$ (-20 to +19.9 $^{\circ}\text{C}$ ) $\pm 0.75\text{ }^{\circ}\text{C}$ (+20 to +99.9 $^{\circ}\text{C}$ ) $\pm 0.75\%$ of mv (+100 to +950 $^{\circ}\text{C}$ )	$\pm 0.75\text{ }^{\circ}\text{C}$ (-35 to +75 $^{\circ}\text{C}$ ) $\pm 1\%$ of mv (+75.1 to +950 $^{\circ}\text{C}$ )
Resolution	0.1 $^{\circ}\text{C}$	0.1 $^{\circ}\text{C}$
Measurement rate	t95: 150 ms; Scanning Max/Min/Alarm: 100 ms	Oper. temp. -20 to +50 $^{\circ}\text{C}$ Storage temp. -40 to +70 $^{\circ}\text{C}$
Meas. spot marking	Cross-laser in the far-field 2-point laser in close focus	Battery type 2 AA batteries Battery life 25 h (without laser), 10 h (with laser without light), 5 h (with laser and 50% light)
Emission factor	Adjustable 0.1 to 1.0	Material/Housing black/gray, metal screen
Distance to measurement spot	Far field: 75:1 16 mm @ 1200 mm (90%) Close focus: 1 mm @ 70 mm (90%)	Dimensions 155 x 58 x 195 mm Weight 465 g Warranty 2 years

Accessories	Part no.
Humidity module, upgradeable for testo 845	0636 9784
Plug-in mains adapter, 5 VDC 500 mA with European adapter, 100-250 VAC, 50-60 Hz	0554 0447
External fast charger for 1-4 AA rech. batteries, incl. 4 Ni-MH rech. batteries with individual cell charging and charge control display, incl. impulse trickle charging, integrated discharge function, with built-in international mains plug, 100-240 V, 300 mA, 50/60 Hz	0554 0610
Testo printer with wireless infrared interface, 1 roll of thermal paper and 4 AA batteries, for printout of reading on site	0554 0547
Spare thermal paper for printer (6 rolls), measurement data documentation legible for up to 10 years	0554 0568
testo saline pots for control and humidity adjustment of humidity probes, 11.3 %RH and 75.3 %RH with adapter for humidity probe, quick checks or calibration of humidity probe	0554 0660
Adhesive tape e.g. for polished surfaces (roll, 10 m long, 25 mm wide), E = 0.95, temperature resistant up to +300 $^{\circ}\text{C}$	0554 0051
Silicone heat paste (14g), T <sub>max</sub> = +260 $^{\circ}\text{C}$ , improves heat transfer in surface probes	0554 0004
ISO calibration certificate/temperature, infrared thermometer, calibration points +60 $^{\circ}\text{C}$ ; +120 $^{\circ}\text{C}$ ; +180 $^{\circ}\text{C}$	0520 0002
ISO calibration certificate/temperature, Infrared thermometers, calibration points -18 $^{\circ}\text{C}$ , 0 $^{\circ}\text{C}$ , +60 $^{\circ}\text{C}$	0520 0401
ISO calibration certificate/temperature, Meas. instr. with air/immersion probe; cal. points 0 $^{\circ}\text{C}$ ; +150 $^{\circ}\text{C}$ ; +300 $^{\circ}\text{C}$ (Applies only to immersion/penetration probe 0602 2693)	0520 0021

Probes see page 44/45

Air probes	Illustration	Meas. range	Accuracy	t99	Part no.
Robust air probe, T/C Type K		-60 to +400 °C	Class 2*	25 s	0602 1793
<b>Immersion/penetr. probes</b>	<b>Illustration</b>	<b>Meas. range</b>	<b>Accuracy</b>	<b>t99</b>	<b>Part no.</b>
Efficient and fast-action immersion probe, waterproof, TC Type K		-60 to +1000 °C	Class 1*	2 s	0602 0593
Fast-action, waterproof immersion/penetration probe, TC Type K (Calibration not possible over +300 °C)		-60 to +800 °C	Class 1*	3 s	0602 2693
Immersion tip, flexible, TC Type K		-200 to +1000 °C	Class 1*	5 s	0602 5792
Immersion measurement tip, flexible, for measurements in air/exhaust gases (not suitable for measurements in smelters), TC Type K		-200 to +1300 °C	Class 1*	4 s	0602 5693
Immersion tip, flexible, TC Type K		-200 to +40 °C	Class 3*	5 s	0602 5793
Waterproof immersion/penetration probe, TC Type K		-60 to +400 °C	Class 2*	7 s	0602 1293
<b>Surface probes</b>	<b>Illustration</b>	<b>Meas. range</b>	<b>Accuracy</b>	<b>t99</b>	<b>Part no.</b>
Fast-reaction paddle surface probe, for measurements in inaccessible places, e.g. narrow apertures and slots, TC Type K		0 to +300 °C	Class 2*	5 s	0602 0193
Fast-action surface probe with sprung thermocouple strip, also for uneven surfaces, measurement range short-term to +500°C, TC Type K		-60 to +300 °C	Class 2*	3 s	0602 0393
Waterproof surface probe with widened measurement tip for flat surfaces, T/C Type K		-60 to +400 °C	Class 2*	30 s	0602 1993
Fast-action surface probe with sprung thermocouple strip, bent, also for uneven surfaces, measurement range short-term to +500°C, TC Type K		-60 to +300 °C	Class 2*	3 s	0602 0993
Efficient, waterproof surface probe with small measurement head for flat surfaces, TC Type K		-60 to +1000 °C	Class 1*	20 s	0602 0693
Flat head surface probe with telescopic handle max. 680 mm for measurements at hard-to-access points, TC Type K		-50 to +250 °C	Class 2*	3 s	0602 2394
Magnetic probe, adhesive force approx. 20 N, with magnets, for measurements on metal surfaces, TC Type K		-50 to +170 °C	Class 2*	150 s	0602 4792
Magnetic probe, adhesive force approx. 10 N, with magnets, for higher temp., for measurements on metal surfaces, TC Type K		-50 to +400 °C	Class 2*		0602 4892
Pipe wrap probe with Velcro strip, for temperature measurement on pipes with diameter up to max. 120 mm, Tmax +120°C, TC Type K		-50 to +120 °C	Class 1*	90 s	0628 0020
Pipe wrap probe for pipe diameter 5 to 65 mm, with exchangeable measuring head. Meas. range short-term to +280°C, TC Type K		-60 to +130 °C	Class 2*	5 s	0602 4592
Spare meas. head for pipe wrap probe, TC Type K		-60 to +130 °C	Class 2*	5 s	0602 0092
Clamp probe for measurements on pipes, pipe diameter 15 to 25 mm (max. 1"), meas. range short-term up to +130°C, TC Type K		-50 to +100 °C	Class 2*	5 s	0602 4692

\*According to standard EN 60584-2, the accuracy of Class 1 refers to -40 to +1000 °C (Type K), Class 2 to -40 to +1200 °C (Type K), Class 3 to -200 to +40 °C (Type K)

**testo 830-T2/-T3/-T4 • testo 845**
**Probes**

Food probes	Illustration	Meas. range	Accuracy	t <sub>99</sub>	Part no.
Waterproof food probe made of stainless steel (IP65), TC Type K	<p>125 mm 30 mm Ø 4 mm Ø 3.2 mm</p> <p>Conn.: Fixed cable</p>	-60 to +400 °C	Class 2*	7 s	0602 2292
Robust food probe with special handle, IP 65, reinforced cable (PUR), T/C Type K	<p>115 mm 30 mm Ø 5 mm Ø 3.5 mm</p> <p>Conn.: Fixed cable</p>	-60 to +400 °C	Class 1*	6 s	0602 2492
Waterproof robust immersion/penetration probe with metal protection hose T <sub>max</sub> +230°C, e.g. for monitoring temp. in cooking oil, T/C Type K	<p>240 mm Ø 4 mm</p> <p>Conn.: Fixed cable</p>	-50 to +230 °C	Class 1*	15 s	0628 1292

Thermocouples	Illustration	Meas. range	Accuracy	t <sub>99</sub>	Part no.
Thermocouple with TC adapter, flexible, 800mm long, fibre glass, TC Type K	<p>800 mm Ø 1.5 mm</p>	-50 to +400 °C	Class 2*	5 s	0602 0644
Thermocouple with TC adapter, flexible, 1500mm long, fibre glass, TC Type K	<p>1500 mm Ø 1.5 mm</p>	-50 to +400 °C	Class 2*	5 s	0602 0645
Thermocouple with TC adapter, flexible, 1500mm long, Teflon, TC Type K	<p>1500 mm Ø 1.5 mm</p>	-50 to +250 °C	Class 2*	5 s	0602 0646

\*According to standard EN 60584-2, the accuracy of Class 1 refers to -40 to +1000 °C (Type K), Class 2 to -40 to +1200 °C (Type K), Class 3 to -200 to +40 °C (Type K)

## testo 880

With a thermal resolution  $<0.1^{\circ}\text{C}$ , perfectly developed electronics for the optimum utilization of the detector, and the image interpolation to  $320 \times 240$  pixels, the testo 880 delivers high definition images which satisfy even the most demanding user. The optimum exploitation of the IR radiation is guaranteed by the high-quality germanium optics. An exchangeable protective glass prevents damage to the valuable optics.

testo 880-1 and testo 880-2, with an integrated digital camera and image-in-image function, links real and IR images for fast, safe and easy documentation.

The easy creation of file structures reduces to a minimum the administrative effort for the planning and management of the images, measurement sites and tours.

The clearly structured and user-friendly PC software offers the comprehensive analysis and evaluation of thermograms. You can now process, analyze and document several parallel infrared images in a thermography report together with their respective real images.

In order to achieve precise analysis results, it is possible to correct the thermal image according to the different emissivities of the various materials by area, right up to individual pixels.

## Thermal imager with highest image quality



Easy joystick operation for navigating through menu and image gallery



Image-in-image function for easier orientation and simple documentation

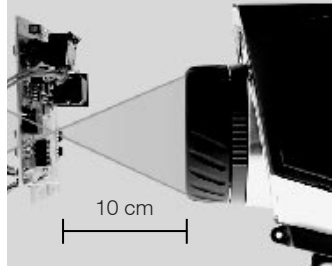

Very short minimum focus distance of approx. 10 cm for small objects



### testo 880-1

The starter instrument for fast fault-finding and quality assurance

- High-quality wide angle lens  $32^{\circ} \times 24^{\circ}$  with F1 optics
- Detector  $160 \times 120$
- NETD  $<0.1^{\circ}\text{C}$
- Minimum focus distance 10 cm
- Data storage device SD, 1 GB for approx. 800-1000 images

- Built-in digital camera
- Image refresh rate 9 Hz
- Manual focus

Part no.  
**0563 0880 V1**

### testo 880-2

The professional thermal imager with extensive analysis functions, extendable by telephoto lens

- High-quality wide angle lens  $32^{\circ} \times 24^{\circ}$  with F1 optics
- Detector  $160 \times 120$
- NETD  $<0.1^{\circ}\text{C}$
- Minimum focus distance 10 cm
- Data storage device SD, 1 GB for approx. 800-1000 images

- 33 Hz- version (inside EU, 9 Hz outside)
- Manual focus
- Exchangeable lenses
- Display of surface moisture distribution
- Lens protection glass

Part no.  
**0563 0880 V2**

### testo 880-3

The expert's thermal imager for complete analysis and real image documentation

- High-quality wide angle lens  $32^{\circ} \times 24^{\circ}$  with F1 optics
- Detector  $160 \times 120$
- NETD  $<0.1^{\circ}\text{C}$
- Minimum focus distance 10 cm
- Data storage device SD, 1 GB for approx. 800-1000 images

- Built-in digital camera with power LED's
- 33 Hz- version (inside EU, 9 Hz outside)
- Dynamic motor focus
- Exchangeable lenses
- Display of surface moisture distribution
- Lens protection glass
- Real-time display of surface moisture distribution with wireless humidity probe (optional)\*

Part no.  
**0563 0880 V3**

### testo 880-3 Pro-Set

testo 880-3 Pro-Set  
The expert's thermal imager with unbeatable price advantage

Additionally to the delivery scope of testo 880-3, the set contains:

- One telephoto lens  $12^{\circ} \times 9^{\circ}$ ,
- One additional battery,
- One fast charger,
- The sunshield.

Part no.  
**0563 0880 V4**

### Ordering information

	Order code	testo 880-1 0563 0880 V1	testo 880-2 0563 0880 V2	testo 880-3 0563 0880 V3	testo 880-3 Pro-Set 0563 0880 V4
Additionally in case					
Lens protection glass	C1	●	●	●	●
Telephoto lens	A1	–	●	●	●
Additional battery	D1	●	●	●	●
Fast charger	E1	●	●	●	●
Sunshield	F1	●	●	●	●
Humidity measurement	B1	–	–	●	●

All imagers are delivered in a robust case including SD card, USB cable, software, mains unit and adapter plate for tripod mounting.

● Standard

● Optional

– Not available

Please select the version of the thermal imager testo 880 which suits your individual needs best from the above options; for example a testo 880-1 with additional lens protection glass, additional battery and fast charger.

This combination results in the order code:

**0563 0880 V1 C1 D1 E1**

**testo 880**

Technical data	testo 880-1	testo 880-2	testo 880-3
<b>Image specifications</b>			
<b>Infrared</b>			
Optical field/min. focus distance	32° x 24° / 0,1 m (standard lens), 12° x 9° / 0,6 m (telephoto lens)		
Thermal sensitivity (NETD)	<0,1 °C at 30 °C		
Geometric resolution	3,5 mrad (standard lens), 1,3 mrad (telephoto lens)		
Image refresh rate	9 Hz	9 Hz outside, 33 Hz inside EU	
Focus	manual		manual + motorized
Detector type	FPA 160 x 120 pixels, a.Si, temperature-stabilized		
Spectral range	8 to 14 µm		
<b>Visual</b>			
Optical field/min. focus distance	33,2° x 25,2° / 0,4 m		33,2° x 25,2° / 0,4 m
Image size	640 x 480 Pixel		640 x 480 Pixel
Image refresh rate	8 ... 15 Hz		8 ... 15 Hz
<b>Image presentation</b>			
Image display	3.5" LCD with 320 x 240 Pixel		
Display options	IR image only / real image only / IR and real image	IR image only	IR image only / real image only / IR and real image
Video output	USB 2.0		
Video stream	9 Hz	25 Hz	
Colour palettes	8 options		
<b>Measurement</b>			
Temperature range	-20 to +100 °C 0 to +350 °C (switchable)		
Accuracy	±2 °C, ±2% of mv		
Minimum diameter measurement point	10 mm at 1 m (standard lens), standard 4 mm at 1 m (telephoto lens)		
Switch-on time	40 s		
Humidity measurement and air temperature measurement with wireless probe (optional)			0 to 100 %RH / -20 to +70 °C td -20 to +70 °C (air temperature with NTC)
Accuracy wireless probe	±2 %RH / ±0,5 °C (air temperature)		
Measurement functions	Standard measurement (1-point), 2-point measurement, Hot/Cold Spot recognition Display of surface moisture distribution via manual input of humidity Optional humidity measurement with wireless humidity probe		
Reflected temperature compensation	manual		
Setting emissivity	Nine materials programmable, of which one user-defined (0.01 - 1.0)		
<b>Image storage</b>			
File format	.bmt; export possibility to in .bmp, .jpg, .csv		
Data storage device	SD card		
Store capacity	1 GB (approx. 800-1.000 images)		
<b>Optics</b>			
Standard lens (32°)		yes	
Telephoto lens (12°)	no		yes, optional
<b>Laser measurement spot marking</b>			
Classification of laser	635nm, Class 2		
<b>Current supply</b>			
Battery type	Fast charging, Li-ion battery, changeable on site		
Operating time	approx 5 h at 20 °C		
Charging options	in instrument/charger (optional)		
Mains operation	yes		
Output voltage	5 V / 4 A		
<b>Ambient conditions</b>			
Operating temperature range	-15 to +40 °C		
Storage temperature range	-30 to +60 °C		
Air humidity	20 % to 80 %RH non-condensing		
Protection class of housing	IP54		
<b>Physical characteristics</b>			
Weight	900 g		
Dimensions	152 x 106 x 262 mm		
Tripod mounting	yes, with adapter, included in delivery		
Housing	ABS, diecast zinc		
<b>PC software</b>			
System requirements	Windows XP (Service Pack 2), Windows Vista, interface USB 2.0		
<b>Norms, tests, warranty</b>			
EU guideline	2004 / 108 / EG		
Warranty	2 years		

Accessories	Part no.
<b>Aluminium tripod;</b> Professional, extremely light and stable aluminium tripod with quick release legs and 3-way tripod head	0554 8804
<b>Lens protection glass;</b> Special protective glass made of germanium, for optimum protection against dust and scratches	0554 8805
<b>Additional battery;</b> Additional Lithium-ion battery to prolong operating time	0554 8802
<b>Fast charger;</b> Desktop fast charger for two batteries to optimize charging time	0554 8801
<b>Sunshield;</b> Special sunshield for the display of the testo 880 in bright surroundings	0554 8806
<b>Retrofit telephoto lens;</b> (for testo 880-2 and -3); please contact our customer service	On request
<b>Emission adhesive tape;</b> Adhesive tape e.g. for polished surfaces (roll, 10 m long, 25 mm wide), E = 0.95, temperature resistant up to +300°C	0554 0051

Accessories	Part no.
<b>Retrofit wireless humidity measurement (for testo 880-3 only)</b> 869.85 MHz FSK (For the countries AT, BE, BG, CH, CY, CZ, DE, DK, EE, ES, FI, FR, GB, GR, HU, IE, IT, LT, LU, LV, MT, NL, NO, PL, PT, RO, SE, SI, SK, TR, ZA)	0554 8811
915 MHz FSK (For the countries BR, CA, CL, CO, MX)	0554 8812
<b>ISO calibration certificate for testo 880</b>	
Calibration points at 0 °C, 25 °C, 50 °C in measuring range -20 °C to 100 °C	0520 0489
Calibration points at 0 °C, 100 °C, 200 °C in measuring range 0 °C to 350 °C	0520 0490
Freely selectable calibration points in the range -18 °C to 250 °C	0520 0495

## testo 805

## Mini infrared thermometer, pocket-size (1:1 optics)

The compact 80 mm infrared thermometer fits into any pocket and is always within reach e.g. for measurements in Incoming goods and for checking the cold shelves in supermarkets. Also ideal for rapid measurements in the food industry and in the home.

- Practical and compact, pocket-size
- High accuracy in the critical range for food
- Water-proof and robust on account of dishwasher-safe protection sleeve TopSafe (IP65)
- Minimum and maximum value display
- Scan mode for long-term measurements



testo 805, Mini infrared thermometer and battery

Part no.  
**0560 8051**

### Technical data

Probe type	Integrated infrared sensor
Meas. range	-25 to +250 °C
Accuracy	±3 °C (-25 to -21 °C)
±1 digit	±2 °C (-20 to -2.1 °C)
	±1 °C (-2 to +40 °C)
	±1.5 °C (+40.1 to +150 °C)
	±2% of mv (+150.1 to +250 °C)
Distance to measurement spot	1:1
Resolution	0.1 °C (-9.9 to +199.9 °C) 1 °C (remaining range)

Oper. temp.	0 to +50 °C
Storage temp.	-20 to +65 °C
Material/Housing	ABS
Battery type	1 x lithium type: CR 2032
Battery life	40 h (typical)
Reaction time	< 1.0 s
Emissivity	0.95 (adjustable to 0.95 or 1.00)
Dimensions	80 x 31 x 19 mm
Weight	28 g

### Set

Set for fast inspections	Part no.
testo 805 Mini infrared thermometer, TopSafe and battery	0563 8051

### Accessories

Accessories	Part no.
TopSafe, robust, waterproof protection case (IP65)	0516 8051
ISO calibration certificate/Temperature, Infrared thermometers, calibration points 0°C, +60°C	0520 0452



**testo 826-T1**
**Infrared food thermometer (6:1 optics)**

testo 826-T1 for non-contact and quick temperature checks on food - packaging is not damaged. The adjustable alarm (flashing display) indicates immediately if a limit value has been exceeded.

- Screening test - measurement, without damaging the packaging
- Small and practical
- Upper and lower limit value monitoring with optical alarm (flashing display)
- Included: TopSafe (IP67) protection case, robust and hygienic, dishwasher-safe
- TopSafe case protects the instrument from dust, dirt and water ingress
- Wall/belt holder included
- Water-proof and robust thanks to TopSafe (IP67)



**testo 826-T1, Infrared thermometer without sighting, with TopSafe and wall/belt holder**

Part no.  
**0563 8261**

**Technical data**

Meas. range	-50 to +300 °C
Spectral range	8 to 14 µm
Accuracy ±1 digit	±1.5 °C (-20 to +100 °C) ±2 °C or 2% of mv (remaining range)
Resolution	0.5 °C
Measurement rate	0,5 s
Distance to measurement spot	6:1
Emissivity	0.95 fixed

Oper. temp.	0 to +50 °C
Storage temp.	-40 to +70 °C
Battery type	2 lithium batteries (CR2032)
Battery life	Approx. 150 h
Dimensions	148 x 34.4 x 19 mm
Display	LCD, 1 line
Weight	80 g
Warranty	2 years

**Accessories**

ISO calibration certificate/temperature, Infrared thermometers, calibration points -18°C, 0°C, +60°C

**Part no.**

0520 0401

**testo 826-T2**
**Infrared food thermometer with laser sighting (6:1 optics)**

In addition to the above advantages of testo 826-T1, testo 826-T2 has laser sighting and an audible alarm which signals when a fixed limit value has been exceeded.

- Screening test - measurement, without damaging the packaging
- Small and practical
- Upper and lower limit value monitoring with optical alarm (flashing display)
- Included: TopSafe (IP67) protection case, robust and hygienic, dishwasher-safe
- TopSafe case protects the instrument from dust, dirt and water ingress
- Wall/belt holder included
- Water-proof and robust thanks to TopSafe (IP67)



Spot is marked by laser beam

Audible alarm if limit value is exceeded

**testo 826-T2, Infrared thermometer with laser sighting and audible alarm, incl. TopSafe and wall/belt holder**

Part no.  
**0563 8262**

**Technical data**

Meas. range	-50 to +300 °C
Spectral range	8 to 14 µm
Accuracy ±1 digit	±1.5 °C (-20 to +100 °C) ±2 °C or 2% of mv (remaining range)
Resolution	0.5 °C
Measurement rate	0,5 s
Distance to measurement spot	6:1
Emissivity	0.95 fixed
Meas. spot marking	1-point laser

Oper. temp.	-20 to +50 °C
Storage temp.	-40 to +70 °C
Battery type	2 AAA micro batteries
Battery life	Approx. 20 h
Dimensions	148 x 34.4 x 19 mm
Display	LCD, 1 line
Weight	80 g
Warranty	2 years

**Accessories**

ISO calibration certificate/temperature, Infrared thermometers, calibration points -18°C, 0°C, +60°C

**Part no.**

0520 0401

## testo 826-T3

testo 826-T3, quick non-contact measurement and core temperature measurement in one instrument. The surface temperature is measured with the infrared side while the measuring tip on the penetration side is used to determine the core temperature.

**testo 826-T3, 2 in 1 thermometer incl. TopSafe, wall/belt holder, probe protection cap and frozen food drill**

Part no.  
**0563 8263**

## Infrared thermometer with penetration probe (6:1 optics)

- Penetration thermometer and non-contact infrared thermometer in one compact instrument
- Spot check with infrared side without damaging packaging
- Core temperature measurement with thin, robust measuring tip
- Upper and lower limit value monitoring with optical alarm (flashing display)
- TopSafe case protects instrument from dust, dirt, impact and water ingress



Only in combination with TopSafe

### Technical data

Probe type	Infrared	NTC
Meas. range	-50 to +300 °C	-50 to +230 °C
Spectral range	8 to 14 µm	
Accuracy	±1.5 °C (-20 to +100 °C)	±0.5 °C (-20 to +99.9 °C)
±1 digit	±2 °C or 2% of mv (remaining range)	±1 °C or 1% of mv (remaining range)
Resolution	0.5 °C	0.1 °C
Measurement rate	0,5 s	1,25 s
Emissivity	0.95 fixed	
Distance to measurement spot	6:1	
		Battery life Approx. 100 h
		Display LCD, 1 line
Oper. temp.	0 to +50 °C	Weight 80 g
Storage temp.	-40 to +70 °C	Dimensions 148 x 34.4 x 19 mm
Battery type	2 lithium batteries (CR2032)	Warranty 2 years

### Accessories

Accessories	Part no.
ISO calibration certificate/temperature, for air/immersion probes, calibration point -18°C	0520 0061
ISO calibration certificate/temperature, for air/immersion probes, calibration point 0°C	0520 0062
ISO calibration certificate/temperature, For air/immersion probes, calibration points -18°C; +60°C	0520 0043
ISO calibration certificate/temperature, for air/immersion probes, calibration points -18°C; 0°C; +60°C	0520 0001
ISO calibration certificate/temperature, Infrared thermometers, calibration points -18°C, 0°C, +60°C	0520 0401
ISO calibration certificate/temperature, Infrared thermometers, calibration points 0°C, +60°C	0520 0452

## testo 826-T4

testo 826-T4 is the top model from the testo 826 series. In addition to the above-mentioned benefits of testo 826-T3, testo 826-T4 also has a laser sighting and a reliable audible alarm.

**testo 826-T4, 2 in 1 thermometer with laser and alarm, TopSafe, wall/belt holder, protection cap and frozen food drill**

Part no.  
**0563 8264**

## Infrared thermometer with penetration probe and laser sighting (6:1 optics)

- Penetration thermometer and non-contact infrared thermometer in one compact instrument
- Spot check with infrared side without damaging packaging
- Core temperature measurement with thin, robust measuring tip
- Upper and lower limit value monitoring with optical alarm (flashing display)
- TopSafe case protects instrument from dust, dirt, impact and water ingress



Only in combination with TopSafe

### Technical data

Probe type	Infrared	NTC
Meas. range	-50 to +300 °C	-50 to +230 °C
Spectral range	8 to 14 µm	
Accuracy	±1.5 °C (-20 to +100 °C)	±0.5 °C (-20 to +99.9 °C)
±1 digit	±2 °C or 2% of mv (remaining range)	±1 °C or 1% of mv (remaining range)
Resolution	0.5 °C	0.1 °C
Measurement rate	0,5 s	1,25 s
Distance to measurement spot	6:1	
		Battery type 2 AAA micro batteries
		Battery life Approx. 15 h
Emissivity	0.95 fixed	Display LCD, 1 line
Meas. spot marking	1-point laser	Weight 80 g
Oper. temp.	-20 to +50 °C	Dimensions 148 x 34.4 x 19 mm
Storage temp.	-40 to +70 °C	Warranty 2 years

### Accessories

Accessories	Part no.
ISO calibration certificate/temperature, for air/immersion probes, calibration point -18°C	0520 0061
ISO calibration certificate/temperature, for air/immersion probes, calibration point 0°C	0520 0062
ISO calibration certificate/temperature, For air/immersion probes, calibration points -18°C; +60°C	0520 0043
ISO calibration certificate/temperature, for air/immersion probes, calibration points -18°C; 0°C; +60°C	0520 0001
ISO calibration certificate/temperature, Infrared thermometers, calibration points -18°C, 0°C, +60°C	0520 0401
ISO calibration certificate/temperature, Infrared thermometers, calibration points 0°C, +60°C	0520 0452

**testo 831**
**Distance thermometer for infrared monitoring measurements in the food sector (30:1 optics)**

Thanks to its 30:1 optics, the measurement spot diameter is only 3.6 cm at a distance of 1 m. This means that even small objects such as yoghurt pots can be easily measured at a distance. Measurement errors are avoided due to a 2-point laser which indicates the exact measurement spot. At two measurements per second, the testo 831 is so fast that measurements on palletes or refrigerated shelves can be carried out in seconds.

- Infrared thermometer with 30:1 optics
- Broad measurement range of -30 to +210 °C
- Backlit display
- Alarm limit values can be set and are optically and audibly indicated
- Including belt holder and factory calibration certificate
- Also available as a set with the core thermometer testo 106

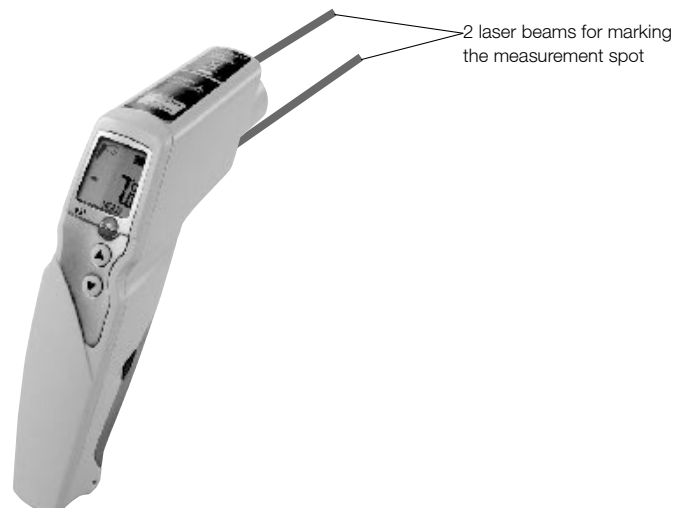

testo 831, infrared thermometer including belt holder, battery, instruction manual and factory calibration certificate with the measurement points -20 and +80 °C

**Set with testo 831 and testo 106**

Set testo 831 and testo 106 - Infrared thermometer including belt holder, battery, instruction manual and factory calibration certificate with the measurement points -20 and +80 °C, and penetration thermometer testo 106 including TopSafe, belt holder, battery and instruction manual

Part no.  
**0560 8310**

Part no.  
**0563 8310**

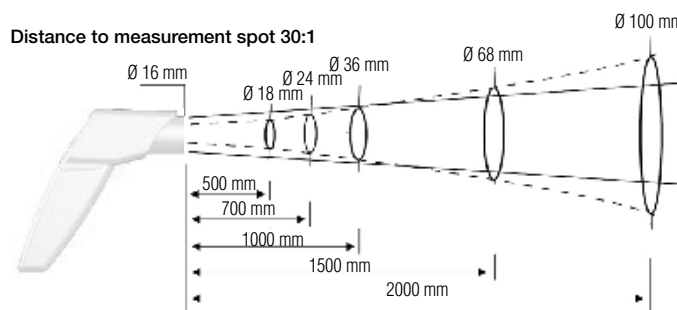

Technical data	
Probe type	Infrared
Meas. range	-30 to +210 °C
Spectral range	8 to 14 µm
Accuracy ±1 digit	±1,5 °C or ±1,5% of mv (-20 to +210 °C) ± 2 °C or ±2% of mv (remaining range)
Resolution	0,5 °C
Measurement rate	0,5 s
Distance to measurement spot	30:1
Emissivity	Adjustable 0.2 to 1.0

Oper. temp.	-20 to +50 °C
Storage temp.	-40 to +70 °C
Battery type	9V block battery
Battery life	15 h
Display	Illuminated LCD
Protection class	IP30
Dimensions	190 x 75 x 38 mm
Weight	200 g
Warranty	2 years

Accessories	Part no.
ISO calibration certificate/temperature, Infrared thermometers, calibration points -18°C, 0°C, +60°C	0520 0401
ISO calibration certificate/Temperature, Infrared thermometers, calibration points 0°C, +60°C	0520 0452
9V rech. battery for instrument instead of battery	0515 0025
Recharger for 9V rechargeable battery for external recharging of 0515 0025 battery	0554 0025

**testo Saveris base**

The base is the heart of testo Saveris and can save 40,000 readings per measurement channel independent of the PC. This corresponds to around one year of memory capacity at a measuring rate of 15 minutes. An emergency battery ensures that an alarm is transmitted and that no existing data is lost in the event of a power failure.

The system data and alarms are visible via the display of the Saveris base. Even without the PC running, the base issues an alarm by means of an LED if the limit value is exceeded, or optionally via SMS and via a relay output to which an alarm transmitter can be connected.

In total, a base can incorporate 150 radio and Ethernet probes or 254 measurement channels. The Saveris base is connected to the PC either via USB or Ethernet cable. The Saveris base thereby offers flexibility with the highest data security.

**testo Saveris wireless probe**

The testo Saveris radio probes measure temperature and humidity. In the measuring cycle, the probes save the recorded measurement data and send it to the central base at regular intervals. If a limit value is exceeded, a radio link is established immediately. Through bidirectional transmission, the radio probe and the base are in mutual contact. This therefore ensures that the measurement data is only recorded by the base and is not interfered with by other radio systems.

An alarm sounds in the event that the radio link be interrupted by obstacles. The memory in the probe ensures that the measurement data is not lost in the event of an interference in the radio link. An optimized battery design ensures for long running life of the probe memory.

In free field, the transmission path is approx. 300 m at a frequency of 868 MHz and approx. 100 m at a frequency of 2.4 GHz. In buildings, the transmission path is strongly influenced by structural conditions such as walls, refrigerator doors or metal doors. The radio link can be improved or lengthened with poor structural conditions by using a router. Because the radio probe and the router show the quality of their radio link, the probe can personally be positioned optimally by the user.

Probe versions with internal and external sensors allow the adaptation to every application. The radio probes are available with or without a display as an option. Current measurement data, the battery status and the quality of the radio link are shown on the display.

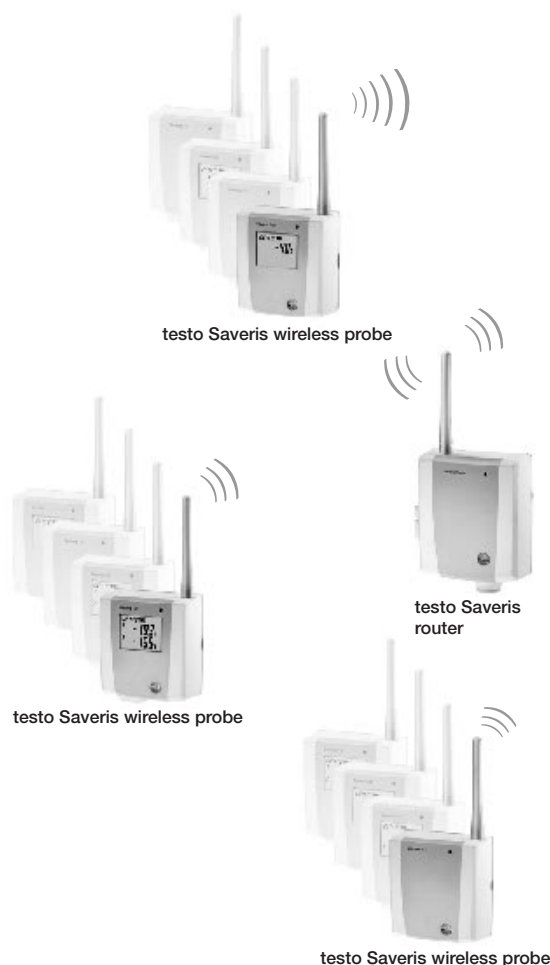
**testo Saveris wireless probe**
**Saveris set 1**
**Set 1, 868 MHz**

Set 1: 868 MHz, consisting of base 0572 0120, 3 NTC radio probes without display 0572 1110, mains unit for base 0554 1096 and SBE software 0572 0180 incl. USB cable

Part no.  
**0572 0110**

**Set 1, 2.4 GHz**

Set 1: 2.4 GHz, consisting of base 0572 0160, 3 NTC radio probes without display 0572 1150, mains unit for base 0554 1096 and SBE software 0572 0180 incl. USB cable

Part no.  
**0572 0150**

**Saveris set 2**
**Set 2, 868 MHz**

Set 2: 868 MHz, consisting of base 0572 0120, 5 NTC radio probes with display 0572 1120, router 0572 0119, 2 mains units for base and router 0554 1096 and SBE software 0572 0180 incl. USB cable

Part no.  
**0572 0111**

**Set 2, 2.4 GHz**

Set 1: 2.4 GHz, consisting of base 0572 0160, 3 NTC radio probes without display 0572 1150, mains unit for base 0554 1096 and SBE software 0572 0180 incl. USB cable

Part no.  
**0572 0151**

**Saveris set 3**
**Set 3, 868 MHz**

Set 3: 868 MHz, consisting of base 0572 0121 incl. GSM module for SMS alarm, aerial with magnetic base 0554 0525, 5 NTC radio probes with display 0572 1120, router 0572 0119, 2 mains units for base and router 0554 1096 and SBE software 0572 0180 incl. USB cable

Part no.  
**0572 0112**

**Set 3, 2.4 GHz**

Set 3: 2.4 GHz, consisting of base 0572 0161 incl. GSM module for SMS alarm, aerial with magnetic base 0554 0525, 5 NTC radio probes with display 0572 1160, router 0572 0159, 2 mains units for base and router 0554 1096 and SBE software 0572 0180 incl. USB cable

Part no.  
**0572 0152**

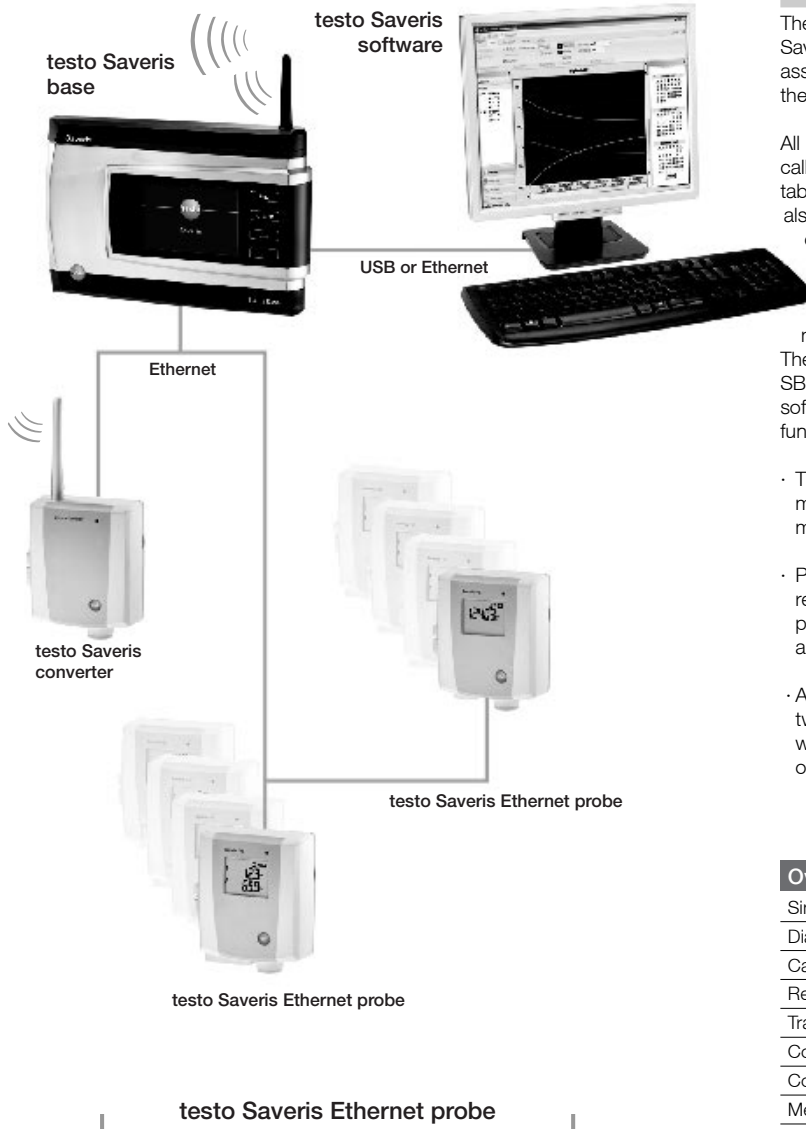
**testo Saveris™**

**testo Saveris software**

The measurement data is transmitted from the base to a PC on which the testo Saveris software is installed within just a few minutes using an installation assistant. The initial system and probe configuration is also performed using the software.

All measurement are saved centrally in the software's database and can be called up any time as a table or a graph. All alarms that occur are listed in a table as a history. The automatic creation of PDF reports in defined intervals also simplifies the documentation. Using the calendar function and the consolidation of probes into groups, the operation of the software is simple and intuitive.

In the event of an alarm the user can choose between receiving a message via e-mail or an alarm directly on the screen. The Saveris software is available in two different versions. The basic version SBE (Small Business Edition) enables the appeal basic functions of the software. Die PROF (Professional) software version offers interesting additional functions, e.g.:

- The integration into the network via Ethernet. Constant monitoring of the measurement data is thereby possible. The measurement data can be monitored by various PCs integrated into the network.
- Photographs of machines or rooms can be saved as a picture. The respective measurement values are shown directly at the position of the probe in the room or at the machine in these. The link between the location and the measurement value is thus very easily visualized (s. picture).
- A comprehensive alarm management offers the option of alarming more than two people at the same time or in succession. Depending on the day of the week and the time, you can freely choose whether an alarm is sent via e-mail or SMS.

Overview of software versions	SBE	PROF
Simple installation and configuration	•	•
Diagrams/tables/alarm overview/PDF reports	•	•
Calendar management	•	•
Representation of probe group	•	•
Transmission of alarms (e-mail, SMS, relay)	•	•
Comprehensive alarm management		•
Constant monitoring in PC continuous operation		•
Measurement data on background photo of locations		•
Integration into network (client-server)		•

**testo Saveris Ethernet probe**

In addition to the radio probes, probes can be used that are directly connected to the Ethernet. The existing LAN infrastructure can be used through this. This allows the data transfer from the probe to the base, even over long distances.

Ethernet probes can be used over any long periods since they are connected to the mains and therefore work independently of batteries. The internal memory guarantees that the existing measurement data is not lost, even with failure of the mains or the LAN connection.

A display informs about the current measurement data as well as the probe status. Different probe versions (probe partially plug-in) adapt to the conditions of the application.

Through the connection of a converter to an Ethernet jack, the signal of a radio probe can be converted into an Ethernet signal. This combines the flexible connection of the radio probe with the use of the existing Ethernet even over long transmission paths.

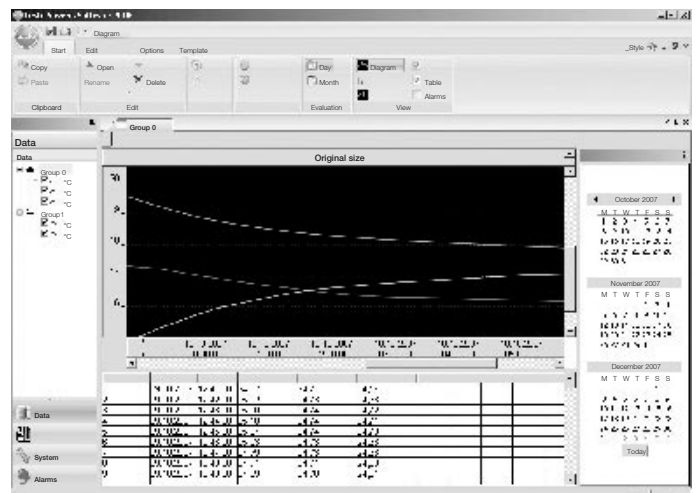

Probe versions with internal and external temperature sensors and with humidity sensors allow the adaptation to every application. The radio probes are available with or without a display as an option. Current measurement data, the battery status and the quality of the radio link are shown in the display.



°C				%RH, °C	
<b>NTC</b> internal		<b>NTC</b> internal	<b>NTC</b> external	<b>Pt 100</b> external	<b>%RH</b> <b>NTC</b> internal
<b>Saveris T1</b>	Radio probe with internal NTC	<b>Saveris T2</b>	Radio probe with external probe connection and internal NTC, door contact	<b>Saveris Pt</b>	Radio probe with 1 external Pt100 probe connection
		<b>Saveris T3</b>	2-channel radio probe with 2 external TC probe connections (Choice of TC characteristics)		<b>Saveris H3</b>
					Humidity radio probe





<b>Internal sensor</b>	<b>Probe type</b>	<b>NTC</b>	<b>NTC</b>			<b>NTC</b>	Humidity sensor
	<b>Meas. range</b>	-35 to +50 °C	-35 to +50 °C			-20 to +50 °C	0 to 100 %RH
	<b>Accuracy</b>	±0.4 °C (-25 to +50 °C) ±0.8 °C (remaining range)	±0.4 °C (-25 to +50 °C) ±0.8 °C (remaining range)			±0.5 °C	±3 %RH
	<b>Resolution</b>	0.1 °C	0.1 °C			0.1 °C / 0.1 °C td	0.1%
<b>External probe</b>	<b>Probe type</b>		<b>NTC</b>	<b>TC type K</b>	<b>TC type J</b>	<b>Pt100</b>	
	<b>Meas. range (Instrument)</b>		-50 to +150 °C	-195 to +1350 °C	-100 to +750 °C	-200 to +600 °C	
	<b>Accuracy (Instrument)</b>		±0.2 °C (-25 to +70 °C) ±0.4 °C (remaining range)	±0.5 °C or 0.5% of mv	±0.5 °C or 0.5% of mv	at 25 °C ±0.1 °C (0 to +60 °C) ±0.2 °C (-100 to +200 °C) ±0.5 °C (remaining range)	
	<b>Resolution</b>		0.1 °C	0.1 °C / <b>TC type S</b> 1 °C	0.01 °C		
<b>Connection</b>		NTC via mini-DIN socket, door contact connection cable included in delivery (1.80 m)	2 TCs via TC socket, max. difference in potential 2 V		1 Pt100 via mini-DIN socket		
<b>Dimensions (housing):</b>	80 x 85 x 38 mm						
<b>Weight</b>	Approx. 240 g						
<b>Battery type</b>	4 AA batteries						
<b>Battery life</b>	Battery life at +25 °C, 3 years; for freezer applications, 3 years with L91 Photo lithium Energizer batteries						
<b>Material/Housing</b>	Plastic						
<b>Protection class</b>	IP68	IP68	IP54	IP68	IP68	IP42	
<b>Radio frequency</b>	868 MHz / 2.4 GHz						
<b>Measuring rate</b>	Standard 15 min, 1 min to 24 h can be set						
<b>Conformity with standards</b>	DIN EN 12830						
<b>Oper. temp.</b>	-35 to +50 °C		-20 to +50 °C				
<b>Storage temp.</b>	-40 to +55 °C						
<b>Display (optional)</b>	LCD, 2 lines; 7-segment with symbols						
<b>Transmission distance</b>	approx. 300 m free field at a frequency of 868 MHz, approx. 100 m free field at a frequency of 2.4 GHz						
<b>Wall bracket</b>	included						

Versions		<b>Saveris T1</b>	<b>Saveris T2</b>	<b>Saveris T3</b>	<b>Saveris Pt</b>	<b>Saveris H3</b>
<b>868 MHz</b>	Version without display	Part no. 0572 1110	Part no. 0572 1111	Part no. 0572 9112	Part no. 0572 7111	Part no. 0572 6110
	Version with display	<b>Saveris T1 D</b> Part no. 0572 1120	<b>Saveris T2 D</b> Part no. 0572 1121	<b>Saveris T3 D</b> Part no. 0572 9122	<b>Saveris Pt D</b> Part no. 0572 7121	<b>Saveris H3 D</b> Part no. 0572 6120
<b>2.4 GHz</b>	Version without display	Part no. 0572 1150	Part no. 0572 1151	Part no. 0572 9152	Part no. 0572 7151	Part no. 0572 6150
	Version with display	<b>Saveris T1 D</b> Part no. 0572 1160	<b>Saveris T2 D</b> Part no. 0572 1161	<b>Saveris T3 D</b> Part no. 0572 9162	<b>Saveris Pt D</b> Part no. 0572 7161	<b>Saveris H3 D</b> Part no. 0572 6160

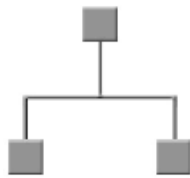
The AA alkali manganese mignon batteries (0515 0414) are contained in this ordering data.



The existing LAN infrastructure can be used through the Ethernet probe. This allows the data transfer from the probe to the base, even over long distances. Ethernet probes have a display.

**Ethernet**

	°C		%RH, °C				
							
	<b>Pt 100</b> external	<b>TC</b> external	<b>%RH NTC</b> external	<b>%RH NTC</b> external			
	<b>Saveris Pt E</b> Ethernet probe with external Pt100 probe connection	<b>Saveris T4 E</b> 4-channel Ethernet probe with 4 external TC probe connections	<b>Saveris H2 E</b> Humidity Ethernet probe 2 %	<b>Saveris H1 E</b> Humidity Ethernet probe 1 %			
<b>External probe</b>	<b>Probe type</b>	<b>Pt100</b>	<b>TC type T</b> <b>TC type S</b>	<b>Humidity sensor</b> <b>NTC</b>	<b>Humidity sensor</b> <b>NTC</b>	<b>Humidity sensor</b> <b>NTC</b>	
	<b>Meas. range</b> (Instrument)	-200 to +600 °C	-200 to +400 °C   0 to +1760 °C	0 to 100 %RH*   -20 to +70 °C	0 to 100 %RH*   -20 to +70 °C	0 to 100 %RH*   -20 to +70 °C	
	<b>Accuracy</b> (Instrument)	at 25 °C ±0.1 °C (0 to +60 °C) ±0.2 °C (-100 to +200 °C) ±0.5 °C (remaining range)	±0.5 °C or 0.5% of mv -195 to +1350 °C   -100 to +750 °C	to 90 %RH: ±2 %RH > 90 %RH: ±3 %RH	±0.5 °C	to 90 %RH: ±(1 %RH +0.7 % of mv) at +25 °C > 90 %RH: ±(1.4 %RH +0.7 % of mv) at +25 °C	±0.2 °C (0 to +30 °C) ±0.5 °C (remaining range)
	<b>Resolution</b>	0.01 °C	0.1 °C / <b>TC type S</b> 1 °C	0.1% / 0.1 °C td	0.1 °C	0.1% / 0.1 °C td	0.1 °C
<b>Connection</b>	Mini-DIN service interface for adjustment is accessible externally						
	1 Pt100 via mini-DIN socket	4 TCs via TC socket, max. difference in potential 50 V					
<b>Dimensions (housing):</b>	Approx. 85 x 100 x 38 mm						
<b>Weight</b>	Approx. 220 g	Approx. 220 g	Approx. 230 g	Approx. 230 g			
<b>Power supply (absolutely necessary)</b>	6.3 V DC mains unit; alternatively via 24 V AC/DC plug-in/screw terminals						
<b>Buffer battery</b>	Li-ion						
<b>Material/Housing</b>	Plastic						
<b>Protection class</b>	IP54						
<b>Measuring rate</b>	2 s to 24h						
<b>Oper. temp.</b>	-20 to +60 °C						
<b>Storage temp.</b>	-40 to +60 °C						
<b>Display</b>	LCD, 2 lines; 7-segment with symbols						
<b>Wall bracket</b>	included						
	<b>Saveris Pt E</b> With display Part no. 0572 7191	<b>Saveris T4 E</b> With display Part no. 0572 9194	<b>Saveris H2 E</b> With display Part no. 0572 6192	<b>Saveris H1 E</b> With display Part no. 0572 6191			

No mains units are contained in this ordering data

\*not for continuous high-humidity applications

Accessories	Part no.
Programming adapter (from mini-DIN to USB) for Ethernet probe and converter (necessary if no DHCP server available)	0440 6723
<b>Sintered caps for Saveris H1 E and H2 E Ethernet probes</b>	
Metal protection cage, Ø 12 mm for humidity probes, for measurement in flow velocities of less than 10 m/s	 0554 0755
Cap with wire mesh filter, Ø 12 mm	 0554 0757
Sintered Teflon filter, Ø 12 mm, for corrosive media, High humidity range (long-term measurements), high flow velocities.	 0554 0756
testo saline pots for control and humidity adjustment of humidity probes, 11.3 %RH and 75.3 %RH with adapter for humidity probe, quick checks or calibration of humidity probe	0554 0660



testo Saveris™ Base	Part no.
Saveris base, radio frequency 868 MHz	0572 0120
Saveris base, radio frequency 868 MHz, GSM module integrated (for SMS alarm)	0572 0121
Saveris base, radio frequency 2.4 GHz	0572 0160
Saveris base, radio frequency 2.4 GHz, GSM module integrated (for SMS alarm)	0572 0161

No mains units or aerials with magnetic base are contained in this ordering data.



Technical data Base	
Memory	40,000 values per channel (total max. 10,160,000 values)
Dimensions	225 x 150 x 49 mm
Weight	Approx. 1510 g
Protection class	IP42
Material/Housing	Diecast zinc / plastic
Radio frequency	868 MHz / 2.4 GHz
Power supply (absolutely necessary)	6.3 V DC mains unit; alternatively via 24 V AC/DC plug-in/screw terminals, power consumption < 4 W
Rech. batt.	Li-ion battery (for data back-up and for emergency SMS if power supply fails)
Oper. temp.	-10 to +50 °C
Storage temp.	-40 to +60 °C
Display	graphical display, 4 control keys
Interfaces	USB, radio, Ethernet
Connectable radio probe	max. 15 probes can be directly connected via radio interface, max. 150 total via radio / router / converter / Ethernet, max. 254 channels
Alarm relay	max. 1 A, max. 30 W, max. 60/25 V DC/AC, NC or NO contact
GSM module	850 / 900 / 1800 / 1900 MHz not valid for Japan and South Korea
Set up	Table base and wall bracket included

#### Note on the radio frequencies

868 MHz: EU countries and certain other countries (e.g. CH, NOR)  
2.4 GHz: non-EU countries (country list can be called up under [www.testo.com/saveris](http://www.testo.com/saveris))

Power supply	Part no.
Battery for radio probe (4 AA alkali manganese mignon batteries)	0515 0414
Battery for radio probe for use below -10 °C (4 Energizer L91 Photo lithium)	0515 0572
100-240 V AC / 6.3 V DC international mains unit; for mains operation or battery charging in instrument	0554 1096
Mains unit (top-hat rail mounting) 90 to 264 VAC/24 VDC (2.5 A)	0554 1749
Mains unit (desk-top) 110 to 240 VAC/24 VDC (350mA)	0554 1748

Other features	Part no.
Magnetic foot aerial (dualband) with 3 m cable, for base with GSM module (not suitable for USA, Canada, Chile, Argentina, Mexico)	0554 0524
Magnetic foot aerial (quadband) for base with GSM module	0554 0525
Alarm module (visual + acoustic), can be connected to base alarm relay, Ø 70 x 164 mm, 24 V AC/DC / 320 mA, perm. light: red, perm. tone: buzzer approx. 2.4 kHz (Mains unit 0554 1749 required)	0572 9999 ID-Nr. 0699 6111/1

testo Saveris™ Router	Part no.
Saveris router, 868 MHz, radio transmission medium	0572 0119
Saveris router, 2.4 GHz, radio transmission medium	0572 0159

testo Saveris™ Converter	Part no.
Saveris converter, 868 MHz, converts the radio transmission medium to Ethernet	0572 0118
Saveris converter, 2.4 GHz, converts the radio transmission medium to Ethernet	0572 0158

No mains units are contained in this ordering data.

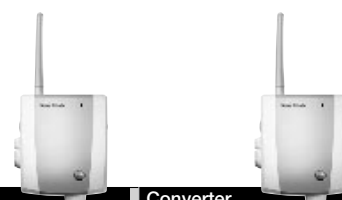

Technical data	Router	Converter
Dimensions	Approx. 85 x 100 x 38 mm	Approx. 85 x 100 x 35 mm
Weight	Approx. 180 g	Approx. 190 g
Power supply	6.3 V DC mains unit; alternatively via 24 V AC/DC plug-in/screw terminals, power consumption < 0.5 W	6.3 V DC mains unit; alternatively via 24 V AC/DC plug-in/screw terminals, power consumption < 2 W
Oper. temp.	-20 to +50 °C	-20 to +50 °C
Storage temp.	-40 to +60 °C	-40 to +60 °C
Material/Housing	Plastic	Plastic
Protection class	IP54	IP54
Interfaces	Radio	Radio, Ethernet
Connectable radio probe	max. 5	max. 15
Wall bracket	included	included

Accessories	Part no.
Programming adapter (from mini-DIN to USB) for Ethernet probe and converter (necessary if no DHCP server available)	0440 6723

Software	Part no.
SBE software, incl. USB connecting cable base-PC	0572 0180
PROF software, incl. USB connecting cable base-PC	0572 0181
Saveris adjustment software incl. connection cable for wireless and Ethernet probes	0572 0183
Measurement data view via Internet	0572 0184

Calibration Certificates	Part no.
ISO calibration certificate/temperature; Temperature probes; calibration points -8 °C; 0 °C; +40 °C per channel/instrument (suitable for Saveris T1/T2)	0520 0171
ISO calibration certificate/temperature; Temperature probes; calibration points -18 °C; 0 °C; +60 °C; per channel/instrument (not suitable for Saveris T1/T2)	0520 0151
DKD calibration certificate/temperature; Temperature probes; calibration points -20 °C; 0 °C; +60 °C; per channel/instrument (not suitable for Saveris T1/T2)	0520 0261
ISO calibration certificate humidity; Humidity data logger; calibration points 11.3 %RH and 75.3 %RH at +25 °C/+77 °F; per channel/instrument	0520 0076
DKD calibration cert./humidity; humidity data logger; cal. points 11.3%RH and 75.3%RH at +25°C; per channel/instrument	0520 0246



**testo Saveris™**
**Accessories: External temperature probes**

Pt 100	Plug-in probes	Illustration	Meas. range	Accuracy	t99	Part no.
◆	Robust, Pt100 stainless steel food probe (IP65)	 Conn.: Fixed cable	-50 to +400 °C	Class A (-50 to +300 °C), Class B (remaining range)	10 s	0609 2272
◆	Robust, waterproof Pt100 immersion/penetration probe	 Fixed cable	-50 to +400 °C	Class A (-50 to +300 °C), Class B (remaining range)	12 s	0609 1273
Connection cable for unlimited Pt100 stationary probes with screw terminals (4-wire technology), max. cable length: 20 m						0554 0213
TC	Plug-in probes	Illustration	Meas. range	Accuracy	t99	Part no.
◆	Stationary probe with stainless steel sleeve, TC Type K	 Conn.: Fixed cable 1.9 m	-50 to +205 °C	Class 2*	20 s	0628 7533
◆	Robust air probe, T/C Type K	 Conn.: Fixed cable 1.2 m	-60 to +400 °C	Class 2*	25 s	0602 1793
	Magnetic probe, adhesive force approx. 20 N, with magnets, for measurements on metal surfaces, TC Type K	 Fixed cable	-50 to +170 °C	Class 2*	150 s	0602 4792
	Magnetic probe, adhesive force approx. 10 N, with magnets, for higher temp., for measurements on metal surfaces, TC Type K	 Conn.: Fixed cable 1.6 m	-50 to +400 °C	Class 2*		0602 4892
	Pipe wrap probe for pipe diameter 5 to 65 mm, with exchangeable measuring head. Meas. range short-term to +280°C, TC Type K	 Conn.: Fixed cable 1.2 m	-60 to +130 °C	Class 2*	5 s	0602 4592
	Pipe wrap probe with Velcro strip, for temperature measurement on pipes with diameter up to max. 120 mm, Tmax +120°C, TC Type K	 Conn.: Fixed cable 1.5 m	-50 to +120 °C	Class 1*	90 s	0628 0020
	Thermocouple with TC adapter, flexible, 800mm long, fibre glass, TC Type K	 Conn.: Fixed cable	-50 to +400 °C	Class 2*	5 s	0602 0644
	Thermocouple with TC adapter, flexible, 1500mm long, fibre glass, TC Type K	 Conn.: Fixed cable	-50 to +400 °C	Class 2*	5 s	0602 0645
	Thermocouple with TC adapter, flexible, 1500mm long, Teflon, TC Type K	 Conn.: Fixed cable	-50 to +250 °C	Class 2*	5 s	0602 0646
	Immersion tip, flexible, TC Type K	 Conn.: Fixed cable	-200 to +1000 °C	Class 1*	5 s	0602 5792
	Immersion measurement tip, flexible, for measurements in air/exhaust gases (not suitable for measurements in smelters), TC Type K	 Conn.: Fixed cable	-200 to +1300 °C	Class 1*	4 s	0602 5693
◆ The specified accuracy class of the Saveris radio and Ethernet probe is achieved using these external probes.			*According to standard EN 60584-2, the accuracy of Class 1 refers to -40 to +1000 °C (Type K), Class 2 to -40 to +1200 °C (Type K), Class 3 to -200 to +40 °C (Type K).			
NTC	Plug-in probes	Illustration	Meas. range	Accuracy	t99	Part no.
◆	Stub probe, IP 54	 Conn.: Fixed cable	-20 to +70 °C	±0.2 °C (-20 to +40 °C) ±0.4 °C (+40.1 to +70 °C)	15 s	0628 7510
◆	Stationary probe with aluminium sleeve, IP 65	 Conn.: Fixed cable; Cable/length: 2.4 m	-30 to +90 °C	±0.2 °C (0 to +70 °C) ±0.5 °C (remaining range)	190 s	0628 7503*
◆	Accurate imm./pen. probe, 6m cable, IP 67	 Conn.: Fixed cable; Cable/length: 6 m	-35 to +80 °C	±0.2 °C (-25 to +74.9 °C) ±0.4 °C (remaining range)	5 s	0610 1725*
◆	Accurate immersion/penetration probe, cable: 1.5 m long, IP 67	 Conn.: Fixed cable; Cable/length: 1.5 m	-35 to +80 °C	±0.2 °C (-25 to +74.9 °C) ±0.4 °C (remaining range)	5 s	0628 0006*
	Wall surface temperature probe, e.g. to prove damage in building material	 Conn.: Fixed cable; Cable/length: 3 m	-50 to +80 °C	±0.2 °C (0 to +70 °C)	20 s	0628 7507
◆	Stainless steel NTC food probe (IP65) with PUR cable	 Conn.: Fixed cable; Cable/length: 1.6 m	-50 to +150 °C <sup>2)</sup>	±0.5% of mv (+100 to +150 °C) ±0.2 °C (-25 to +74.9 °C) ±0.4 °C (remaining range)	8 s	0613 2211*
◆	Waterproof NTC immersion/penetration probe	 Conn.: Fixed cable	-50 to +150 °C	±0.5% of mv (+100 to +150 °C) ±0.2 °C (-25 to +74.9 °C) ±0.4 °C (remaining range)	10 s	0613 1212
	Pipe wrap probe with Velcro for pipe diameter to max. 75 mm, Tmax. +75°C, NTC	 Conn.: Fixed cable; Cable/length: 1.5 m	-50 to +70 °C	±0.2 °C (-25 to +70 °C) ±0.4 °C (-50 to -25.1 °C)		0613 4611
◆ The specified accuracy class of the Saveris radio and Ethernet probe is achieved using these external probes.			* Probe tested to EN 12830 for suitability in the transport and storage sectors 2) Long-term measurement range +125°C, short-term +150°C or +140°C (2 minutes)			

## testo 174

The testo 174 mini temperature data logger is ideal for accompanying transports. The logger is simply placed beside the product e.g. in aeroplanes, containers, refrigerated rooms etc. and constantly monitors the fluctuations in temperature unobtrusively.

testo 174, Mini temperature data logger, 1 channel, incl. wall holder, lock and battery

Part no.  
**0563 1741**

## Mini data logger

- Secure Data - even if battery is spent
- Current reading is shown on large display
- Data upload to PC or notebook via interface (optional)
- Fast data transfer - Data is read out from memory in 10 s.



### Technical data

Probe type	NTC
Meas. range	-30 to +70 °C
Accuracy ±1 digit	±0.5 °C (-20 to +39.9 °C) ±0.8 °C (remaining range)
Resolution	0.1 °C
Oper. temp.	-30... +70 °C
Storage temp.	-40... +70 °C
Battery type	3V button cell (CR 2032)
Battery life	500 days (typical)
Protection class	IP65
Measuring rate	1 min to 4 h (selectable)

Memory	3900 readings
Display	LCD, 1 line
Weight	24 g
Dimensions	55 x 35 x 14 mm
Warranty	2 years

Battery life: 500 days (typical)

Meas. rate: 1 min to 4 h (selectable)

Software: Microsoft Windows 95b / 98 / ME / NT2-Sp4 / 2000 / XP/Vista

### Set

testo 174 Mini temperature data logger, 1 channel, ComSoft 3 Basic, wall holder, lock, interface incl. PC connection cable, battery

### Part no.

0563 1742

Mini temperature data logger, 1 channel, ComSoft 3 Basic, wall holder, USB interface with PC connection cable and battery

0563 1743

### Accessories

Spare Li battery for testo 174 data logger

### Part no.

0515 0028

ComSoft 3 - Professional with data management, incl. database, analysis and graphics function, data analysis, trend curve

0554 0830

Interface, suitable for testo 174 data logger, incl. PC connection cable

0554 1746

USB interface, suitable for testo 174 data logger, incl. PC connection cable

0554 1739

ISO calibration certificate/temperature, temperature data logger, calibration points -18°C, +60°C

0520 0443

**testo 175-T1**
**Compact data logger**

The testo 175-T1 temperature data logger, ideal for accompanying goods, guarantees uninterrupted documentation of the complete refrigeration chain.

The testo 575 fast printer provides proof that the goods have adhered to the specified temperature. All of the data which have been collected by the testo 580 data collector can be sent to your PC for analysis, if required.

testo 175-T1, temperature data logger, 1 channel with internal sensor, incl. wall holder and calibration protocol

Part no.

**0563 1754**

- Provides quick overview of current reading, last value saved, max/min value, number of times limits exceeded
- Non-volatile memory for secure data, even if battery is spent
- On-site: Fast documentation with infrared printer, 6 lines/s
- On site: Reset and boot up



Actual size

Accessories	Part no.
-------------	----------

Transport and Protection	
--------------------------	--

Lock for wall holder for testo 175/177 data loggers	0554 1755
---	-----------

Additional accessories and spare parts	
--	--

Battery, 3.6 V/1.9 Ah 1AA, for testo 175-T1/175-T2 and all testo 177 loggers	0515 0177
--	-----------

testo 580 data collector set with RS232, readout holders included, for testo 175/177 data loggers	0554 1778
---	-----------

testo 580 data collector set with USB, readout holders included, for testo 175/177 data loggers	0554 1764
---	-----------

testo 581 alarm signal output, floating, for testo 175/177, forwards information efficiently when limits are exceeded to e.g. horns, lamps, PLC etc.	0554 1769
--	-----------

Printer and accessories	
-------------------------	--

Fast testo 575 printer, incl. 1 roll of thermal paper and batteries, infrared thermal line printer with graphics function	0554 1775
---	-----------

Spare thermal paper for printer (6 rolls)	0554 0569
---	-----------

Spare thermal paper for printer (6 rolls), measurement data documentation legible for up to 10 years	0554 0568
--	-----------

Label thermal paper (Testo patent) for testo 575 printer (6 rolls), can be applied directly	0554 0561
---	-----------

Software and accessories	
--------------------------	--

ComSoft 3 - Basic Set with RS232 interface for testo 175, Basic software with diagram and table function, incl. desk-top holder, PC connection cable	0554 1759
--	-----------

ComSoft 3 - Basic Set with USB interface for testo 175, Basic software with diagram and table function, incl. desk-top holders, PC connection cable	0554 1766
---	-----------

ComSoft 3 - Professional with data management, incl. database, analysis and graphics function, data analysis, trend curve (without interface)	0554 0830
---	-----------

ComSoft 3 - For requirements to CFR 21 Part 11, incl. database, analysis and graphics function, data analysis, trend curve (without interface)	0554 0821
--	-----------

RS232 interface for testo 175/177 incl. desk-top holders, PC connection cable, (please also order for ComSoft 3 - Professional)	0554 1757
---	-----------

USB interface, for testo 175/177 incl. desk-top holders, PC conn. cable, (Please order with ComSoft 3 - Professional)	0554 1768
---	-----------

Ethernet adapter, RS232 - Ethernet incl. software driver, mains unit, facilitates data communication in network	0554 1711
---	-----------

Accessories	Part no.
-------------	----------

<b>Calibration certificates</b>	
---------------------------------	--

ISO calibration certificate/temperature, temperature probe; calibration points -18°C; 0°C; +60°C per channel/instrument	0520 0151
---	-----------

DKD calibration certificate/temperature, Temperature probe; cal. points -20°C; 0°C; +60°C (-4 °F, 92 °F, 140 °F); per channel/instrument	0520 0261
--	-----------

Recommended set	
-----------------	--

<b>testo 175-T1, Starter Set</b>	
----------------------------------	--

- testo 175-T1, temperature data logger, 1 channel with internal sensor, incl. wall holder and calibration protocol (Part no. 0563 1754)

- Lock for wall holder for testo 175/177 data loggers (Part no. 0554 1755)

- ComSoft 3 - Basic Set with USB interface for testo 175 (Part no. 0554 1766)

Technical data	
----------------	--

Probe type	NTC (internal)		
Meas. range	-35 to +70 °C	Measuring rate	10 s ... 24 h
Accuracy	±0.5 °C (-20 to +70 °C)	Memory	7800
±1 digit	±1 °C (-35 to -20.1 °C)	Weight	90 g
Resolution	0.1 °C (-20 to +70 °C)	Dimensions	82 x 52 x 30 mm
	0.3 °C (-35 to -20.1 °C)	Warranty	2 years
Oper. temp.	-35 to +70 °C	Battery life: 2.5 years at a measuring cycle of 15 min (-10 to +50°C)	
Storage temp.	-40 to +85 °C	Measuring cycle: 10 s to 24 h	
Battery type	Lithium battery	Software: Microsoft Windows 95b / 98 / ME / 2000 / XP / Vista	
Material/Housing	ABS		
Protection class	IP68		

## testo 175-T2

With an additional external probe connection, the testo 175-T2 temperature data logger provides a further temperature measurement option.

The data logger is attached to the wall to monitor air temperature, for example, and the separate probe is placed by the goods. testo 175-T2 provides information on the connection between ambient and product temperature.

Temperature data logger, 2 channels, with internal sensor and external probe socket, wall holder and calibration protocol

Part no.  
**0563 1755**

## Compact data logger with internal sensor and probe connection

- Monitors 2 temperatures simultaneously
- Fast overview of the current reading, the value last saved, the max/min values, the number of limits exceeded
- User-friendly operation, convenient analysis
- Collect data on site, upload to PC and analyse
- Tamper-proof with wall holder and lock (optional)
- On site: Reset and reboot



Actual size



Probes (NTC)	Illustration	Meas. range	Accuracy	t99	Part no.
● Stub probe, IP 54	35 mm Ø 3 mm	-20 to +70 °C	±0.2 °C (-20 to +40 °C) ±0.4 °C (+40.1 to +70 °C)	15 s	0628 7510
● Stationary probe with aluminium sleeve, IP 65	40 mm Ø 6 mm Conn.: Fixed cable; Cable/length: 2.4 m	-30 to +90 °C	±0.2 °C (0 to +70 °C) ±0.5 °C (remaining range)	190 s	0628 7503*
● Accurate imm./pen. probe, 6m cable, IP 67	40 mm Ø 3 mm Conn.: Fixed cable; Cable/length: 6 m	-35 to +80 °C	±0.2 °C (-25 to +74.9 °C) ±0.4 °C (remaining range)	5 s	0610 1725*
● Accurate immersion/penetration probe, 1.5 m long, IP 67	40 mm Ø 3 mm Conn.: Fixed cable; Cable/length: 1.5 m	-35 to +80 °C	±0.2 °C (-25 to +74.9 °C) ±0.4 °C (remaining range)	5 s	0628 0006*
Probe for surface measurement	40 mm 8 x 8 mm Conn.: Fixed cable; Cable/length: 2 m	-50 to +80 °C	±0.2 °C (0 to +70 °C)	150 s	0628 7516*
Wall surface temperature probe, e.g. to prove damage in building material	Conn.: Fixed cable; Cable/length: 3 m	-50 to +80 °C	±0.2 °C (0 to +70 °C)	20 s	0628 7507
Pipe wrap probe with Velcro for pipe diameter to max. 75 mm, Tmax. +75°C, NTC	300 mm 30 mm Conn.: Fixed cable; Cable/length: 1.5 m	-50 to +70 °C	±0.2 °C (-25 to +70 °C) ±0.4 °C (-50 to -25.1 °C)		0613 4611
● Stainless steel NTC food probe (IP65) with PUR cable	125 mm Ø 4 mm Conn.: Fixed cable; Cable/length: 1.6 m	-50 to +150 °C <sup>2)</sup>	±0.5% of mv (+100 to +150 °C) ±0.2 °C (-25 to +74.9 °C) ±0.4 °C (remaining range)	8 s	0613 2211*
● Stainless steel NTC food probe (IP67) with Teflon cable to +250°C	125 mm Ø 4 mm Conn.: Fixed cable	-50 to +150 °C	±0.5% of mv (+100 to +150 °C) ±0.2 °C (-25 to +74.9 °C) ±0.4 °C (remaining range)	8 s	0613 3311
● Robust NTC food penetration probe with special handle, reinforced PUR cable	115 mm Ø 5 mm Conn.: Fixed cable; Cable/length: 1.4 m	-25 to +150 °C <sup>2)</sup>	±0.5% of mv (+100 to +150 °C) ±0.2 °C (-25 to +74.9 °C) ±0.4 °C (remaining range)	7 s	0613 2411*
● Frozen food probe NTC, corkscrew design (incl. plug-in wire)	110 mm Ø 8 mm Conn.: Plug-in cable	-50 to +140 °C <sup>2)</sup>	±0.5% of mv (+100 to +140 °C) ±0.2 °C (-25 to +74.9 °C) ±0.4 °C (remaining range)	20 s	0613 3211*
● Waterproof NTC immersion/penetration probe	115 mm Ø 5 mm Conn.: Fixed cable	-50 to +150 °C	±0.5% of mv (+100 to +150 °C) ±0.2 °C (-25 to +74.9 °C) ±0.4 °C (remaining range)	10 s	0613 1212

● The specified seal class of the data loggers is achieved with these probes.

\* Probe tested to EN 12830 for suitability in the transport and storage sectors  
2) Long-term measurement range +125°C, short-term +150°C or +140°C (2 minutes)

**testo 175-T2**
**Accessories / Technical data**

Probes (NTC)	Illustration	Meas. range	Accuracy	t99	Part no.
<ul style="list-style-type: none"> <li>Efficient, robust NTC air probe</li> </ul>	<p>115 mm 50 mm 50 mm Ø 5 mm Ø 4 mm</p> <p>Conn.: Fixed cable 1.2 m</p>	-50 to +125 °C	±0.2 °C (-25 to +80 °C) ±0.4 °C (remaining range)	60 s	0613 1712
<ul style="list-style-type: none"> <li>Waterproof NTC surface probe for flat surfaces</li> </ul>	<p>115 mm 50 mm 50 mm Ø 5 mm Ø 6 mm</p> <p>Conn.: Fixed cable 1.2 m</p>	-50 to +150 °C	±0.5% of mv (+100 to +150 °C) ±0.2 °C (-25 to +74.9 °C) ±0.4 °C (remaining range)	35 s	0613 1912
<ul style="list-style-type: none"> <li>Laboratory probe, glass-coated, resistant to corrosive substances, glass stem can be replaced</li> </ul>	<p>200 mm 30 mm Ø 6 mm Ø 5 mm</p> <p>Conn.: Fixed cable</p>	-50 to +150 °C <sup>2)</sup>	±0.5% of mv (+100 to +150 °C) ±0.2 °C (-25 to +74.9 °C) ±0.4 °C (remaining range)	40 s 10 s*	0613 7011
Robust industrial penetration probe for compost, hay, silage and earth measurements	<p>1500 mm Ø 12 mm 20 mm Ø 6 mm</p>	-35 to +120 °C	To UNI curve	16 s	included in set, see below, order no. 0628 0134

\* Probe tested to EN 12830 for suitability in the transport and storage sectors

2) Long-term measurement range +125°C, short-term +150°C or +140°C (2 minutes)

\*\* without protective glass

Accessories	Part no.
<b>Transport and Protection</b>	
Lock for wall holder for testo 175/177 data loggers	0554 1755
<b>Additional accessories and spare parts</b>	
Battery, 3.6 V/1.9 Ah 1AA, for testo 175-T1/175-T2 and all testo 177 loggers	0515 0177
testo 580 data collector set with RS232, readout holders included, for testo 175/177 data loggers	0554 1778
testo 580 data collector set with USB, readout holders included, for testo 175/177 data loggers	0554 1764
testo 581 alarm signal output, floating, for testo 175/177, forwards information efficiently when limits are exceeded to e.g. horns, lamps, PLC etc.	0554 1769
<b>Printer and accessories</b>	
Fast testo 575 printer, incl. 1 roll of thermal paper and batteries, infrared thermal line printer with graphics function	0554 1775
Spare thermal paper for printer (6 rolls)	0554 0569
Spare thermal paper for printer (6 rolls), measurement data documentation legible for up to 10 years	0554 0568
Label thermal paper (Testo patent) for testo 575 printer (6 rolls), can be applied directly	0554 0561
<b>Software and accessories</b>	
ComSoft 3 - Basic Set with RS232 interface for testo 175, Basic software with diagram and table function, incl. desk-top holder, PC connection cable	0554 1759
ComSoft 3 - Basic Set with USB interface for testo 175, Basic software with diagram and table function, incl. desk-top holders, PC connection cable	0554 1766
ComSoft 3 - Professional with data management, incl. database, analysis and graphics function, data analysis, trend curve	0554 0830
ComSoft 3 - For requirements to CFR 21 Part 11, incl. database, analysis and graphics function, data analysis, trend curve (w/o interface)	0554 0821
RS232 interface for testo 175/177 incl. desk-top holders, PC connection cable, (please also order for ComSoft 3 - Professional)	0554 1757
USB interface, for testo 175/177 incl. desk-top holders, PC conn. cable, (Please order with ComSoft 3 - Professional)	0554 1768
Ethernet adapter, RS232 - Ethernet incl. software driver, mains unit, facilitates data communication in network	0554 1711

Accessories	Part no.
<b>Calibration certificates</b>	
ISO calibration certificate/temperature, temperature probe; calibration points -18°C; 0°C; +60°C per channel/instrument	0520 0151
DKD calibration certificate/temperature, Temperature probe; cal. points -20°C; 0°C; +60°C (-4 °F, 92 °F, 140 °F); per channel/instrument	0520 0261
<b>Set</b>	
testostor 175-2, temperature data logger, 2 channels, with internal sensor, robust industrial penetration probe 1.5 m, handles, protection case PP, battery	0628 0134

Recommended set
<b>testo 175-T2, Starter Set</b>
<ul style="list-style-type: none"> <li>Temperature data logger, 2 channels, with internal sensor and external probe socket, wall holder and calibration protocol (Part no. 0563 1755)</li> <li>Lock for wall holder for testo 175/177 data loggers (Part no. 0554 1755)</li> <li>Stationary probe with aluminium sleeve, IP 65 (Part no. 0628 7503)</li> <li>ComSoft 3 - Basic Set with USB interface for testo 175 (Part no. 0554 1766)</li> </ul>
<b>testo 175-T2, Monitoring Set with External Probe</b>
<ul style="list-style-type: none"> <li>Temperature data logger, 2 channels, with internal sensor and external probe socket, wall holder and calibration protocol (Part no. 0563 1755)</li> <li>Lock for wall holder for testo 175/177 data loggers (Part no. 0554 1755)</li> <li>Stainless steel NTC food probe (IP65) with PUR cable (Part no. 0613 2211)</li> <li>ComSoft 3 - Basic Set with USB interface for testo 175 (Part no. 0554 1766)</li> </ul>
<b>testo 175-T2, Set for logging 2 temperatures</b>
<ul style="list-style-type: none"> <li>Temperature data logger, 2 channels, with internal sensor and external probe socket, wall holder and calibration protocol (Part no. 0563 1755)</li> <li>Lock for wall holder for testo 175/177 data loggers (Part no. 0554 1755)</li> <li>Accurate immersion/penetration probe, cable: 1.5 m long, IP 67 (Part no. 0628 0006)</li> <li>ComSoft 3 - Basic Set with USB interface for testo 175 (Part no. 0554 1766)</li> </ul>

Technical data		
Probe type	Chann. intern	Channel, external
	NTC	NTC
Meas. range	-35 to +70 °C	-40 to +120 °C
Accuracy ±1 digit	±0.5 °C (-20 to +70 °C) ±1 °C (remaining range)	±0.3 °C (-25 to +70 °C) ±0.5 °C (remaining range)
Resolution	0.1 °C (-20 to +70 °C) 0.3 °C (remaining range)	0.1 °C (-25 to +70 °C) 0.3 °C (remaining range)

Oper. temp.	-35 to +70 °C	Dimensions	82 x 52 x 30 mm
Storage temp.	-40 to +85 °C	Warranty	2 years
Battery type	Lithium battery	Battery life: 2.5 years at measuring cycle of 15 min (-10 to +50°C)	
Material/Housing	ABS	Measuring cycle: 10 s to 24 h	
Protection class	IP68	Software: Microsoft Windows 95b / 98 / ME / 2000 / XP / Vista	
Memory	16000		
Weight	84 g		

## testo 175-T3

The 175-T3 temperature data logger logs temperature at 2 different points simultaneously over a period of several days, weeks or even months.

The logger provides fast documentation of e.g. temperature fluctuations in industrial processes. Surface, immersion and air probes are available for a wide range of applications.

**testo 175-T3, temperature data logger, 2 channels, with 2 probe sockets, wall holder and calibration protocol**

Part no.  
**0563 1756**

## 2 external temperature probe sockets

- Specially suited to measuring low and high temperatures
- Read out a complete logger at the touch of a button
- Data analysis in table or graphics form, with email function
- Alarm message, reliable transmission of alarm value limits
- Data transfer to PC or notebook by attachable interface (optional)



Probes	Illustration	Meas. range	Accuracy	t99	Part no.
◆ Stationary probe with stainless steel sleeve, TC Type K		-50 to +205 °C	Class 2*	20 s	0628 7533
Pipe wrap probe with Velcro strip, for temperature measurement on pipes with diameter up to max. 120 mm, Tmax +120°C, TC Type K		-50 to +120 °C	Class 1*	90 s	0628 0020
Pipe wrap probe for pipe diameter 5 to 65 mm, with exchangeable measuring head. Meas. range short-term to +280°C, TC Type K		-60 to +130 °C	Class 2*	5 s	0602 4592
Thermocouple with TC adapter, flexible, 800mm long, fibre glass, TC Type K		-50 to +400 °C	Class 2*	5 s	0602 0644
Thermocouple with TC adapter, flexible, 1500mm long, fibre glass, TC Type K		-50 to +400 °C	Class 2*	5 s	0602 0645
◆ Thermocouple with TC adapter, flexible, 1500mm long, Teflon, TC Type K		-50 to +250 °C	Class 2*	5 s	0602 0646
Immersion tip, flexible, TC Type K		-200 to +1000 °C	Class 1*	5 s	0602 5792
Immersion tip, flexible, TC Type K		-200 to +40 °C	Class 3*	5 s	0602 5793
Flexible, low-mass immersion measurement tip, ideal for measurements in small volumes such as petri dishes, or for surface measurements (e.g. attached with adhesive tape), TC Type K		-200 to +1000 °C	Class 1*	1 s	0602 0493
Magnetic probe, adhesive force approx. 10 N, with magnets, for higher temp., for measurements on metal surfaces, TC Type K		-50 to +400 °C	Class 2*		0602 4892
◆ Waterproof immersion/penetration probe, TC Type K		-60 to +400 °C	Class 2*	7 s	0602 1293
◆ Efficient and fast-action immersion probe, waterproof, TC Type K		-60 to +1000 °C	Class 1*	2 s	0602 0593
◆ Robust air probe, T/C Type K		-60 to +400 °C	Class 2*	25 s	0602 1793

◆ The specified seal class of the data loggers is achieved with these probes.

\*According to standard EN 60584-2, the accuracy of Class 1 refers to -40 to +1000 °C (Type K), Class 2 to -40 to +1200 °C (Type K), Class 3 to -200 to +40 °C (Type K).

**testo 175-T3**
**Accessories / Technical data**

Accessories	Part no.
<b>Transport and Protection</b>	
Lock for wall holder for testo 175/177 data loggers	0554 1755
<b>Additional accessories and spare parts</b>	
Battery, 3.6 V/0.8 Ah 1/2 AA, for testo 175-T3/175-H1/175-H2/175-S1/175-S2	0515 0175
testo 580 data collector set with RS232, readout holders included, for testo 175/177 data loggers	0554 1778
testo 580 data collector set with USB, readout holders included, for testo 175/177 data loggers	0554 1764
testo 581 alarm signal output, floating, for testo 175/177, forwards information efficiently when limits are exceeded to e.g. horns, lamps, PLC etc.	0554 1769
<b>Printer and accessories</b>	
Fast testo 575 printer, incl. 1 roll of thermal paper and batteries, infrared thermal line printer with graphics function	0554 1775
Spare thermal paper for printer (6 rolls)	0554 0569
Spare thermal paper for printer (6 rolls), measurement data documentation legible for up to 10 years	0554 0568
Label thermal paper (Testo patent) for testo 575 printer (6 rolls), can be applied directly	0554 0561
<b>Software and accessories</b>	
ComSoft 3 - Basic Set with RS232 interface for testo 175, Basic software with diagram and table function, incl. desk-top holder, PC connection cable	0554 1759
ComSoft 3 - Basic Set with USB interface for testo 175, Basic software with diagram and table function, incl. desk-top holders, PC connection cable	0554 1766
ComSoft 3 - Professional with data management, incl. database, analysis and graphics function, data analysis, trend curve	0554 0830
ComSoft 3 - For requirements to CFR 21 Part 11, incl. database, analysis and graphics function, data analysis, trend curve (w/o interface)	0554 0821
RS232 interface for testo 175/177 incl. desk-top holders, PC connection cable, (please also order for ComSoft 3 - Professional)	0554 1757
USB interface, for testo 175/177 incl. desk-top holders, PC conn. cable, (Please order with ComSoft 3 - Professional)	0554 1768
Ethernet adapter, RS232 - Ethernet incl. software driver, mains unit, facilitates data communication in network	0554 1711
<b>Calibration certificates</b>	
ISO calibration certificate/temperature, temperature probe; calibration points -18°C; 0°C; +60°C per channel/instrument	0520 0151
DKD calibration certificate/temperature, Temperature probe; cal. points -20°C; 0°C; +60°C (-4 °F, 92 °F, 140 °F); per channel/instrument	0520 0261

Recommended set
<b>testo 175-T3, Monitor high temperatures in hardening bays</b>
<ul style="list-style-type: none"> <li>- testo 175-T3, temperature data logger, 2 channels, with 2 probe sockets, wall holder and calibration protocol (Part no. 0563 1756)</li> <li>- Lock for wall holder for testo 175/177 data loggers (Part no. 0554 1755)</li> <li>- 2 x Immersion tip, flexible, TC Type K (Part no. 0602 5792)</li> <li>- testo 580 data collector set with RS232, readout holders included (Part no. 0554 1778 )</li> <li>- ComSoft 3 - Basic Set with USB interface for testo 175 (Part no. 0554 1766)</li> </ul>

testo 175-T3, Temperaturüberwachung von industriellen Prozessen
<ul style="list-style-type: none"> <li>- testo 175-T3, temperature data logger, 2 channels, with 2 probe sockets, wall holder and calibration protocol (Part no. 0563 1756)</li> <li>- Lock for wall holder for testo 175/177 data loggers (Part no. 0554 1755)</li> <li>- 2 x Thermocouple with TC adapter, flexible, 1500mm long, fibre glass, TC Type K (Part no. 0602 0645)</li> <li>- testo 580 data collector set with RS232, readout holders included (Part no. 0554 1778 )</li> <li>- ComSoft 3 - Basic Set with USB interface for testo 175 (Part no. 0554 1766)</li> </ul>

Technical data		
Probe type	Channel, external	
	Type T (Cu-CuNi)	Type K (NiCr-Ni)
Meas. range	-50 to +400 °C	-50 to +1000 °C
Accuracy ±1 digit	±0.7% of mv (+70.1 to +400 °C) ±0.5 °C (-50 to +70 °C)	±0.7% of mv (+70.1 to +1000 °C) ±0.5 °C (-50 to +70 °C)
Resolution	0.1 °C	0.1 °C
Oper. temp.	0 to +70 °C	Dimensions 82 x 52 x 30 mm
Storage temp.	-40 to +85 °C	Warranty 2 years
Battery type	Lithium battery	Battery life: 2.5 years with a measuring cycle of 15 min (-10 to +50°C)
Material/Housing	ABS	Measuring cycle: 10 s to 24 h
Protection class	IP54	Software: Microsoft Windows 95b / 98 / ME / 2000 / XP / Vista
Memory	16000	
Weight	90 g	

## testo 177-T1

## Compact data logger with internal temperature sensor

The testo 177-T1 professional data logger (without display) monitors specified storage and transport conditions in the refrigeration and deep-freeze sector efficiently and accurately over a period of months and years.

Temperature fluctuations which cause damage are documented on the testo 575 fast printer or analysed on your PC via interface.

- Specially for use in low temperatures (up to -40°C)
- On-site: Fast documentation on the infrared printer, 6 lines/s
- Collect data on-site with testo 580 and download to your PC for analysis
- Temperature logging of up to 48,000 readings

testo 177-T1, temperature data logger, 1 channel, with internal sensor, wall holder and calibration protocol

Part no.

**0563 1771**



### Accessories

#### Transport and Protection

Transport case for up to 6 testo 177 data loggers, testo 575 printer, testo 580 data collector and accessories 0516 1770

Lock for wall holder for testo 175/177 data loggers 0554 1755

#### Additional accessories and spare parts

Battery, 3.6 V/1.9 Ah 1AA, for testo 175-T1/175-T2 and all testo 177 loggers 0515 0177

testo 580 data collector set with RS232, readout holders included, for testo 175/177 data loggers 0554 1778

testo 580 data collector set with USB, readout holders included, for testo 175/177 data loggers 0554 1764

testo 581 alarm signal output, floating, for testo 175/177, forwards information efficiently when limits are exceeded to e.g. horns, lamps, PLC etc. 0554 1769

#### Printer and accessories

Fast testo 575 printer, incl. 1 roll of thermal paper and batteries, infrared thermal line printer with graphics function 0554 1775

Spare thermal paper for printer (6 rolls) 0554 0569

Spare thermal paper for printer (6 rolls), measurement data documentation legible for up to 10 years 0554 0568

Label thermal paper (Testo patent) for testo 575 printer (6 rolls), can be applied directly 0554 0561

#### Software and accessories

ComSoft 3 - Basic Set with RS 232 interface for testo 177, Basic software with diagram and table function, incl. desk-top holder, PC connection cable 0554 1774

ComSoft 3 - Basic Set with USB interface for testo 177, Basic software with diagram and table function, incl. desk-top holders, PC connection cable 0554 1767

ComSoft 3 - Professional with data management, incl. database, analysis and graphics function, data analysis, trend curve (without interface) 0554 0830

ComSoft 3 - For requirements to CFR 21 Part 11, incl. database, analysis and graphics function, data analysis, trend curve (w/o interface) 0554 0821

RS232 interface for testo 175/177 incl. desk-top holders, PC connection cable, (please also order for ComSoft 3 - Professional) 0554 1757

USB interface, for testo 175/177 incl. desk-top holders, PC conn. cable, (Please order with ComSoft 3 - Professional) 0554 1768

Ethernet adapter, RS232 - Ethernet incl. software driver, mains unit, facilitates data communication in network 0554 1711

### Accessories

#### Calibration certificates

ISO calibration certificate/temperature, temperature probe; calibration points - 18°C; 0°C; +60°C per channel/instrument 0520 0151

DKD calibration certificate/temperature, Temperature probe; cal. points -20°C; 0°C; +60°C (-4 °F, 92 °F, 140 °F); per channel/instrument 0520 0261

#### Recommended set

##### testo 177-T1, Starter Set

- testo 177-T1, temperature data logger, 1 channel, with internal sensor, wall holder and calibration protocol (Part no. 0563 1771)

- Lock for wall holder for testo 175/177 data loggers (Part no. 0554 1755)

- ComSoft 3 - Basic Set with USB interface for testo 177 (Part no. 0554 1767)

#### Technical data

Probe type	NTC (internal)	Memory	48000
Meas. range	-40 to +70 °C	Weight	111 g
Accuracy	±0.4 °C (-25 to +70 °C)	Dimensions	103 x 64 x 33 mm
±1 digit	±0.8 °C (-40 to -25.1 °C)	Warranty	2 years
Resolution	0.1 °C	Battery lifetime: 5 years at measuring cycle of 15 min (-10 to +50°C)	
Oper. temp.	-40 to +70 °C	Measuring cycle: 2 s to 24 h	
Storage temp.	-40 to +85 °C	Software: Microsoft Windows 95b / 98 / ME / 2000 / XP / Vista	
Battery type	Lithium battery		
Protection class	IP68		



**testo 177-T2**
**Compact data logger with internal temperature sensor**

testo 177-T2, the professional data logger with display. It provides you with a quick overview of the current reading, the last value saved, max and min values and the number of times the limits were exceeded.

All of the values collected by the testo 580 data collector during long-term monitoring over months/years can be sent to your notebook/PC. Convenient analysis possible using software based on Windows®.

testo 177-T2, temperature data logger, 1 channel, with internal sensor, wall holder and calibration protocol

Part no.

**0563 1772**

- Large display, can also be read from a distance
- Non-volatile memory for secure data, even if memory is spent
- On-site: Fast documentation on the infrared printer, 6 lines/s
- Collect data on-site using testo 580 and download to your PC for analysis



Accessories	Part no.
-------------	----------

Transport and Protection	
--------------------------	--

Transport case for up to 6 testo 177 data loggers, testo 575 printer, testo 580 data collector and accessories	0516 1770
--	-----------

Lock for wall holder for testo 175/177 data loggers	0554 1755
---	-----------

Additional accessories and spare parts	
--	--

Battery, 3.6 V/1.9 Ah 1AA, for testo 175-T1/175-T2 and all testo 177 loggers	0515 0177
--	-----------

testo 580 data collector set with RS232, readout holders included, for testo 175/177 data loggers	0554 1778
---	-----------

testo 580 data collector set with USB, readout holders included, for testo 175/177 data loggers	0554 1764
---	-----------

testo 581 alarm signal output, floating, for testo 175/177, forwards information efficiently when limits are exceeded to e.g. horns, lamps, PLC etc.	0554 1769
--	-----------

Printer and accessories	
-------------------------	--

Fast testo 575 printer, incl. 1 roll of thermal paper and batteries, infrared thermal line printer with graphics function	0554 1775
---	-----------

Spare thermal paper for printer (6 rolls)	0554 0569
---	-----------

Spare thermal paper for printer (6 rolls), measurement data documentation legible for up to 10 years	0554 0568
--	-----------

Label thermal paper (Testo patent) for testo 575 printer (6 rolls), can be applied directly	0554 0561
---	-----------

Software and accessories	
--------------------------	--

ComSoft 3 - Basic Set with RS 232 interface for testo 177, Basic software with diagram and table function, incl. desk-top holder, PC connection cable	0554 1774
---	-----------

ComSoft 3 - Basic Set with USB interface for testo 177, Basic software with diagram and table function, incl. desk-top holders, PC connection cable	0554 1767
---	-----------

ComSoft 3 - Professional with data management, incl. database, analysis and graphics function, data analysis, trend curve (without interface)	0554 0830
---	-----------

ComSoft 3 - For requirements to CFR 21 Part 11, incl. database, analysis and graphics function, data analysis, trend curve (w/o interface)	0554 0821
--	-----------

RS232 interface for testo 175/177 incl. desk-top holders, PC connection cable, (please also order for ComSoft 3 - Professional)	0554 1757
---	-----------

USB interface, for testo 175/177 incl. desk-top holders, PC conn. cable, (Please order with ComSoft 3 - Professional)	0554 1768
---	-----------

Ethernet adapter, RS232 - Ethernet incl. software driver, mains unit, facilitates data communication in network	0554 1711
---	-----------

Accessories	Part no.
-------------	----------

Calibration certificates	
--------------------------	--

ISO calibration certificate/temperature, temperature probe; calibration points - 18°C; 0°C; +60°C per channel/instrument	0520 0151
--	-----------

DKD calibration certificate/temperature, Temperature probe; cal. points -20°C; 0°C; +60°C (-4 °F, 92 °F, 140 °F); per channel/instrument	0520 0261
--	-----------

Recommended set	
-----------------	--

testo 177-T2, Starter Set	
---------------------------	--

- testo 177-T2, temperature data logger, 1 channel, with internal sensor, wall holder and calibration protocol (Part no. 0563 1772)
- Lock for wall holder for testo 175/177 data loggers (Part no. 0554 1755)
- ComSoft 3 - Basic Set with USB interface for testo 177 (Part no. 0554 1767)

Technical data			
----------------	--	--	--

Probe type	NTC (internal)	Memory	48000
Meas. range	-40 to +70 °C	Weight	122 g
Accuracy	±0.4 °C (-25 to +70 °C) ±1 digit ±0.8 °C (-40 to -25.1 °C)	Dimensions	103 x 64 x 33 mm
Resolution	0.1 °C	Warranty	2 years
Oper. temp.	-40 to +70 °C	Battery life: 5 years with measuring cycle of 15 min (-10 to +50°C)	
Storage temp.	-40 to +85 °C	Measuring cycle: 2 s to 24 h	
Battery type	Lithium battery	Software: Microsoft Windows 95b / 98 / ME / 2000 / XP / Vista	
Protection class	IP68		

## testo 177-T3

## Internal temperature sensor, 2 external temperature probe sockets and event logging

testo 177-T3 documents 3 temperatures and an event simultaneously providing proof of an uninterrupted cooling chain during transport or when monitoring production processes.

Surface, immersion and air probes make it possible to adapt to the respective measuring task. For example, complete monitoring of ambient air, intake and outgoing temperatures and simultaneous monitoring of the door or compressor is possible when monitoring transports. The measuring cycle of the event can be set completely independently of the measuring cycle for the temperature channels.

- Simultaneous temperature measurement at different sites
- Uninterrupted documentation, also for many years
- Reads out data without interrupting measurement
- Data analysis as table or graph, with e-mail function
- Temperature logging of up to 48,000 readings



testo 177-T3, temperature data logger, 3 channels, with internal sensor, 2 probe sockets, door contact connection cable, wall holder and calibration protocol

Part no.  
**0563 1773**

Probes (NTC)	Illustration	Meas. range	Accuracy	t99	Part no.
● Stub probe, IP 54	35 mm Ø 3 mm	-20 to +70 °C	±0.2 °C (-20 to +40 °C) ±0.4 °C (+40.1 to +70 °C)	15 s	0628 7510
● Stationary probe with aluminium sleeve, IP 65	40 mm Ø 6 mm Conn.: Fixed cable; Cable/length: 2.4 m	-30 to +90 °C	±0.2 °C (0 to +70 °C) ±0.5 °C (remaining range)	190 s	0628 7503*
● Accurate imm./pen. probe, 6m cable, IP 67	40 mm Ø 3 mm Conn.: Fixed cable; Cable/length: 6 m	-35 to +80 °C	±0.2 °C (-25 to +74.9 °C) ±0.4 °C (remaining range)	5 s	0610 1725*
● Accurate immersion/penetration probe, cable: 1.5 m long, IP 67	40 mm Ø 3 mm Conn.: Fixed cable; Cable/length: 1.5 m	-35 to +80 °C	±0.2 °C (-25 to +74.9 °C) ±0.4 °C (remaining range)	5 s	0628 0006*
Probe for surface measurement	40 mm 8 x 8 mm Conn.: Fixed cable; Cable/length: 2 m	-50 to +80 °C	±0.2 °C (0 to +70 °C)	150 s	0628 7516*
Wall surface temperature probe, e.g. to prove damage in building material	30 mm Conn.: Fixed cable; Cable/length: 3 m	-50 to +80 °C	±0.2 °C (0 to +70 °C)	20 s	0628 7507
Pipe wrap probe with Velcro for pipe diameter to max. 75 mm, Tmax. +75°C, NTC	300 mm 30 mm Conn.: Fixed cable; Cable/length: 1.5 m	-50 to +70 °C	±0.2 °C (-25 to +70 °C) ±0.4 °C (-50 to -25.1 °C)		0613 4611
● Stainless steel NTC food probe (IP65) with PUR cable	125 mm Ø 4 mm 15 mm Ø 3 mm Conn.: Fixed cable; Cable/length: 1.6 m	-50 to +150 °C <sup>2)</sup>	±0.5% of mv (+100 to +150 °C) ±0.2 °C (-25 to +74.9 °C) ±0.4 °C (remaining range)	8 s	0613 2211*

● The specified seal class of the data loggers is achieved with these probes.

\* Probe tested to EN 12830 for suitability in the transport and storage sectors  
2) Long-term measurement range +125°C, short-term +150°C or +140°C (2 minutes)

**testo 177-T3**
**Accessories / Technical data**

Probes (NTC)	Illustration	Meas. range	Accuracy	t99	Part no.
<ul style="list-style-type: none"> <li>Robust NTC food penetration probe with special handle, reinforced PUR cable</li> </ul>	<p>Conn.: Fixed cable; Cable/length: 1.4 m</p>	-25 to +150 °C <sup>2)</sup>	±0.5% of mv (+100 to +150 °C) ±0.2 °C (-25 to +74.9 °C) ±0.4 °C (remaining range)	7 s	0613 2411*
<ul style="list-style-type: none"> <li>Frozen food probe NTC, corkscrew design (incl. plug-in wire)</li> </ul>	<p>Conn.: Plug-in cable</p>	-50 to +140 °C <sup>2)</sup>	±0.5% of mv (+100 to +140 °C) ±0.2 °C (-25 to +74.9 °C) ±0.4 °C (remaining range)	20 s	0613 3211*
<ul style="list-style-type: none"> <li>Efficient, robust NTC air probe</li> </ul>	<p>Conn.: Fixed cable 1.2 m</p>	-50 to +125 °C	±0.2 °C (-25 to +80 °C) ±0.4 °C (remaining range)	60 s	0613 1712

\* The specified seal class of the data loggers is achieved with these probes.

\* Probe tested to EN 12830 for suitability in the transport and storage sectors  
 2) Long-term measurement range +125°C, short-term +150°C or +140°C (2 minutes)

Accessories	Part no.
<b>Transport and Protection</b>	
Transport case for up to 6 testo 177 data loggers, testo 575 printer, testo 580 data collector and accessories	0516 1770
Lock for wall holder for testo 175/177 data loggers	0554 1755
<b>Additional accessories and spare parts</b>	
Battery, 3.6 V/1.9 Ah 1AA, for testo 175-T1/175-T2 and all testo 177 loggers	0515 0177
testo 580 data collector set with RS232, readout holders included, for testo 175/177 data loggers	0554 1778
testo 580 data collector set with USB, readout holders included, for testo 175/177 data loggers	0554 1764
testo 581 alarm signal output, floating, for testo 175/177, forwards information efficiently when limits are exceeded to e.g. horns, lamps, PLC etc.	0554 1769
<b>Printer and accessories</b>	
Fast testo 575 printer, incl. 1 roll of thermal paper and batteries, infrared thermal line printer with graphics function	0554 1775
Spare thermal paper for printer (6 rolls)	0554 0569
Spare thermal paper for printer (6 rolls), measurement data documentation legible for up to 10 years	0554 0568
Label thermal paper (Testo patent) for testo 575 printer (6 rolls), can be applied directly	0554 0561
<b>Software and accessories</b>	
ComSoft 3 - Basic Set with RS 232 interface for testo 177, Basic software with diagram and table function, incl. desk-top holder, PC connection cable	0554 1774
ComSoft 3 - Basic Set with USB interface for testo 177, Basic software with diagram and table function, incl. desk-top holders, PC connection cable	0554 1767
ComSoft 3 - Professional with data management, incl. database, analysis and graphics function, data analysis, trend curve (without interface)	0554 0830
ComSoft 3 - For requirements to CFR 21 Part 11, incl. database, analysis and graphics function, data analysis, trend curve (w/o interface)	0554 0821
RS232 interface for testo 175/177 incl. desk-top holders, PC connection cable, (please also order for ComSoft 3 - Professional)	0554 1757
USB interface, for testo 175/177 incl. desk-top holders, PC conn. cable, (Please order with ComSoft 3 - Professional)	0554 1768
Ethernet adapter, RS232 - Ethernet incl. software driver, mains unit, facilitates data communication in network	0554 1711
<b>Calibration certificates</b>	
ISO calibration certificate/temperature, temperature probe; calibration points -18°C; 0°C; +60°C per channel/instrument	0520 0151
DKD calibration certificate/temperature, Temperature probe; cal. points -20°C; 0°C; +60°C (-4 °F, 92 °F, 140 °F); per channel/instrument	0520 0261

Recommended set
<b>testo 177-T3, Temperature monitoring with printout on-site</b>
<ul style="list-style-type: none"> <li>testo 177-T3, temperature data logger, 3 channels, with internal sensor, 2 probe sockets, door contact connection cable, wall holder and calibration protocol (Part no. 0563 1773)</li> <li>Lock for wall holder for testo 175/177 data loggers (Part no. 0554 1755)</li> <li>2 x Stationary probe with aluminium sleeve, IP 65 (Part no. 0628 7503)</li> <li>Fast testo 575 printer, incl. 1 roll of thermal paper and batteries (Part no. 0554 1775)</li> <li>ComSoft 3 - Basic Set with USB interface for testo 177 (Part no. 0554 1767)</li> </ul>

testo 177-T3, Refrigerated room monitoring
<ul style="list-style-type: none"> <li>testo 177-T3, temperature data logger, 3 channels, with internal sensor, 2 probe sockets, door contact connection cable, wall holder and calibration protocol (Part no. 0563 1773)</li> <li>Lock for wall holder for testo 175/177 data loggers (Part no. 0554 1755)</li> <li>2 x Accurate imm./pen. probe, 6m cable, IP 67 (Part no. 0610 1725)</li> <li>Fast testo 575 printer, incl. 1 roll of thermal paper and batteries (Part no. 0554 1775)</li> <li>ComSoft 3 - Basic Set with USB interface for testo 177 (Part no. 0554 1767)</li> </ul>

Technical data		
Probe type	NTC (internal sensor)	NTC (external probes)
Meas. range	-40 to +70 °C	-40 to +120 °C
Accuracy	±0.4 °C (-25 to +70 °C) ±0.8 °C (-40 to -25.1 °C)	±0.2 °C (-25 to +70 °C) ±0.4 °C (remaining range)
Resolution	0.1 °C	0.1 °C

Oper. temp.	-40 to +70 °C
Storage temp.	-40 to +85 °C
Battery type	Lithium battery
Protection class	IP67
Memory	48000
Weight	127 g
Dimensions	103 x 64 x 33 mm
Warranty	2 years

External: Event logging e.g. door contact  
 Battery life: 5 years with meas. rate of 15 min (-10 to +50°C)  
 Measuring rate: 2 s to 24 h  
 Software: Microsoft Windows 95b / 98 / ME / NT4-Sp4 / 2000 / XP / Vista

## testo 177-T4

## Compact data logger with 4 external temperature probe sockets

The testo 177-T4 professional data logger with up to 4 external temperature probe connections for simultaneous temperature measurement at different sites.

Fluctuations in temperature e.g. in production processes, in laboratories etc. often influence the overall result. Surface, immersion and air probes enable adaptation to the respective measurement task.

Temperature data logger, 4 channel, with 4 probe sockets, wall holder and calibration protocol

Part no.  
**0563 1774**

- Specially for use in high and low temperatures
- Read out data without interrupting the measurement series
- Data analysis in table or graphics form, with email function
- Memory for up to 48,000 readings
- Collect data on site, upload to PC and analyse
- Alarm message, efficient indication of limits exceeded
- Memory for up to 48,000 readings



Probes	Illustration	Meas. range	Accuracy	t99	Part no.
◆ Stationary probe with stainless steel sleeve, TC Type K	40 mm Ø 6 mm Conn.: Fixed cable 1.9 m	-50 to +205 °C	Class 2*	20 s	0628 7533
Pipe wrap probe with Velcro strip, for temperature measurement on pipes with diameter up to max. 120 mm, Tmax +120°C, TC Type K	395 mm 20 mm Conn.: Fixed cable 1.5 m	-50 to +120 °C	Class 1*	90 s	0628 0020
Pipe wrap probe for pipe diameter 5 to 65 mm, with exchangeable measuring head. Meas. range short-term to +280°C, TC Type K	800 mm Ø 1.5 mm Conn.: Fixed cable 1.2 m	-60 to +130 °C	Class 2*	5 s	0602 4592
Thermocouple with TC adapter, flexible, 800mm long, fibre glass, TC Type K	800 mm Ø 1.5 mm	-50 to +400 °C	Class 2*	5 s	0602 0644
Thermocouple with TC adapter, flexible, 1500mm long, fibre glass, TC Type K	1500 mm Ø 1.5 mm	-50 to +400 °C	Class 2*	5 s	0602 0645
Thermocouple with TC adapter, flexible, 1500mm long, Teflon, TC Type K	1500 mm Ø 1.5 mm	-50 to +250 °C	Class 2*	5 s	0602 0646
Immersion tip, flexible, TC Type K	500 mm Ø 1.5 mm	-200 to +1000 °C	Class 1*	5 s	0602 5792
Immersion tip, flexible, TC Type K	500 mm Ø 1.5 mm	-200 to +40 °C	Class 3*	5 s	0602 5793
Flexible, low-mass immersion measurement tip, ideal for measurements in small volumes such as petri dishes, or for surface measurements (e.g. attached with adhesive tape), TC Type K	500 mm Ø 0.25 mm Conn.: 2 m, FEP insulated thermal wire, temperature proof up to 200 °C, oval wire with dimensions: 2.2 mm x 1.4 mm	-200 to +1000 °C	Class 1*	1 s	0602 0493
Magnetic probe, adhesive force approx. 10 N, with magnets, for higher temp., for measurements on metal surfaces, TC Type K	75 mm Ø 21 mm Conn.: Fixed cable 1.6 m	-50 to +400 °C	Class 2*		0602 4892
◆ Waterproof immersion/penetration probe, TC Type K	114 mm Ø 5 mm 50 mm Ø 3.7 mm Conn.: Fixed cable 1.2 m	-60 to +400 °C	Class 2*	7 s	0602 1293
◆ Efficient and fast-action immersion probe, waterproof, TC Type K	Ø 1.5 mm 300 mm Conn.: Fixed cable 1.2 m	-60 to +1000 °C	Class 1*	2 s	0602 0593
◆ Robust air probe, T/C Type K	115 mm Ø 4 mm Conn.: Fixed cable 1.2 m	-60 to +400 °C	Class 2*	25 s	0602 1793

◆ The specified seal class of the data loggers is achieved with these probes.

\*According to standard EN 60584-2, the accuracy of Class 1 refers to -40 to +1000 °C (Type K), Class 2 to -40 to +1200 °C (Type K), Class 3 to -200 to +40 °C (Type K).

**testo 177-T4**
**Accessories / Technical data**

Accessories	Part no.
<b>Transport and Protection</b>	
Transport case for up to 6 testo 177 data loggers, testo 575 printer, testo 580 data collector and accessories	0516 1770
Lock for wall holder for testo 175/177 data loggers	0554 1755
<b>Additional accessories and spare parts</b>	
Battery, 3.6 V/1.9 Ah 1AA, for testo 175-T1/175-T2 and all testo 177 loggers	0515 0177
testo 580 data collector set with RS232, readout holders included, for testo 175/177 data loggers	0554 1778
testo 580 data collector set with USB, readout holders included, for testo 175/177 data loggers	0554 1764
testo 581 alarm signal output, floating, for testo 175/177, forwards information efficiently when limits are exceeded to e.g. horns, lamps, PLC etc.	0554 1769
<b>Printer and accessories</b>	
Fast testo 575 printer, incl. 1 roll of thermal paper and batteries, infrared thermal line printer with graphics function	0554 1775
Spare thermal paper for printer (6 rolls)	0554 0569
Spare thermal paper for printer (6 rolls), measurement data documentation legible for up to 10 years	0554 0568
Label thermal paper (Testo patent) for testo 575 printer (6 rolls), can be applied directly	0554 0561
<b>Software and accessories</b>	
ComSoft 3 - Basic Set with RS 232 interface for testo 177, Basic software with diagram and table function, incl. desk-top holder, PC connection cable	0554 1774
ComSoft 3 - Basic Set with USB interface for testo 177, Basic software with diagram and table function, incl. desk-top holders, PC connection cable	0554 1767
ComSoft 3 - Professional with data management, incl. database, analysis and graphics function, data analysis, trend curve (without interface)	0554 0830
ComSoft 3 - For requirements to CFR 21 Part 11, incl. database, analysis and graphics function, data analysis, trend curve (w/o interface)	0554 0821
RS232 interface for testo 175/177 incl. desk-top holders, PC connection cable, (please also order for ComSoft 3 - Professional)	0554 1757
USB interface, for testo 175/177 incl. desk-top holders, PC conn. cable, (Please order with ComSoft 3 - Professional)	0554 1768
Ethernet adapter, RS232 - Ethernet incl. software driver, mains unit, facilitates data communication in network	0554 1711
<b>Calibration certificates</b>	
ISO calibration certificate/temperature, temperature probe; calibration points -18°C; 0°C; +60°C per channel/instrument	0520 0151
DKD calibration certificate/temperature, Temperature probe; cal. points -20°C; 0°C; +60°C (-4 °F, 92 °F, 140 °F); per channel/instrument	0520 0261

Recommended set
<b>testo 177-T4, Monitor high temperatures in production processes</b>
<ul style="list-style-type: none"> <li>- Temperature data logger, 4 channel, with 4 probe sockets, wall holder and calibration protocol (Part no. 0563 1774)</li> <li>- Lock for wall holder for testo 175/177 data loggers (Part no. 0554 1755)</li> <li>- 2 x Immersion tip, flexible, TC Type K (Part no. 0602 5792)</li> <li>- testo 580 data collector set with RS232, readout holders included (Part no. 0554 1778 )</li> <li>- ComSoft 3 - Basic Set with USB interface for testo 177 (Part no. 0554 1767)</li> </ul>

testo 177-T4, Monitor temperature distribution in heat cabinets
<ul style="list-style-type: none"> <li>- Temperature data logger, 4 channel, with 4 probe sockets, wall holder and calibration protocol (Part no. 0563 1774)</li> <li>- Lock for wall holder for testo 175/177 data loggers (Part no. 0554 1755)</li> <li>- 4 x Thermocouple with TC adapter, flexible, 1500mm long, fibre glass, TC Type K (Part no. 0602 0645)</li> <li>- testo 580 data collector set with RS232, readout holders included (Part no. 0554 1778 )</li> <li>- ComSoft 3 - Basic Set with USB interface for testo 177 (Part no. 0554 1767)</li> </ul>

Set for monitoring technical systems
<ul style="list-style-type: none"> <li>- Temperature data logger, 4 channel, with 4 probe sockets, wall holder and calibration protocol (Part no. 0563 1774)</li> <li>- Lock for wall holder for testo 175/177 data loggers (Part no. 0554 1755)</li> <li>- 2 x Pipe wrap probe for pipe diameter 5 to 65 mm, with exchangeable measuring head. Meas. range short-term to +280°C, TC Type K (Part no. 0602 4592)</li> <li>- testo 580 data collector set with RS232, readout holders included (Part no. 0554 1778 )</li> <li>- ComSoft 3 - Basic Set with USB interface for testo 177 (Part no. 0554 1767)</li> </ul>

Technical data	
Meas. range	-200 to +400 °C (Type T (Cu-CuNi)) -200 to +1000 °C (Type K (NiCr-Ni)) -100 to +750 °C (Type J (Fe-CuNi))
Accuracy ±1 digit	±0.5% of mv (+70.1 to +1000 °C) ±1.5% of mv (-200 to -100.1 °C) ±0.3 °C (-100 to +70 °C)
Resolution	0.1 °C

Material/Housing	ABS
Oper. temp.	0 to +70 °C
Storage temp.	-40 to +85 °C
Battery type	Lithium battery
Protection class	IP43
Memory	48000
Weight	129 g
Dimensions	103 x 64 x 33 mm
Warranty	2 years

Battery life: 5 years with measuring cycle of 15 min (-10 to +50°C)  
Measuring cycle: 2 s to 24 h  
Software: Microsoft Windows 95b / 98 / ME / NT4-Sp4 / 2000 / XP / Vista

## testostor 171-0

testostor 171-0 is a temperature data logger in a full-metal housing with built-in temperature probe. A long life is guaranteed even in tough conditions.

The data is read out to a PC via the attachable interface.

testostor 171-0, temperature data logger, incl. starting magnet, battery and calibration protocol

Part no.  
**0577 1719**

## Pro data logger with internal temperature sensor

- Large memory for up to 55,000 readings
- Theft-proof mounting
- Tamperproof readings
- With calibration protocol



Waterproof, robust metal housing, IP68

Accessories	Part no.
<b>Transport and Protection</b>	
Transport case (plastic) for measurement data storage instruments (max. 6 off) and accessories, for safe transport	0516 0117
Holder with lock for data logger, theft-proof	0554 1782
<b>Additional accessories and spare parts</b>	
Spare battery for testostor 171, quick and easy battery replacement	0515 0018
<b>Software and accessories</b>	
ComSoft 3 - Professional with data management, incl. database, analysis and graphics function, data analysis, trend curve	0554 0830
ComSoft 3 - For requirements to CFR 21 Part 11, incl. database, analysis and graphics function, data analysis, trend curve (w/o interface)	0554 0821
Interface, attachable to testostor 171 data logger	0554 1781
Ethernet adapter, RS232 - Ethernet incl. software driver, mains unit, facilitates data communication in network	0554 1711

Accessories	Part no.
<b>Calibration certificates</b>	
ISO calibration certificate/temperature, temperature probe; calibration points -18°C; 0°C; +60°C per channel/instrument	0520 0151
DKD calibration certificate/temperature, Temperature probe; cal. points -20°C; 0°C; +60°C (-4 °F, 92 °F, 140 °F); per channel/instrument	0520 0261
ISO calibration certificate/temperature, temp. data logger; calibration points -8°C; 0°C; +40°C per channel/instrument	0520 0171
ISO calibration cert./temperature, temperature data logger; calibration points selectable from -196 to +1260°C	0520 0141
DKD calibration certificate/temperature, data logger, transmitter, probe without display; cal. points freely selectable from -196 to +1000°C	0520 0281

Technical data			
<b>Probe type</b>	<b>NTC (internal)</b>	Battery type	Lithium battery
Meas. range	-35 to +70 °C	Dimensions	131 x 68 x 26 mm
Accuracy	±0.5 °C (-35 to +39.9 °C) ±1 digit ±0.6 °C (+40 to +70 °C)	Weight	305 g
Resolution	0.1 °C	Protection class	IP68
Oper. temp.	-35 to +70 °C	Warranty	2 years
Storage temp.	-40 to +85 °C	Battery life: lithium battery up to 5 years	
Memory	55000	Software: menu-driven from Microsoft Windows 95 / ME / 2000 / XP / Vista	
Material/Housing	Aluminium, anodized		

**Ex 171-0**
**Data logger for Ex zone with an internal temperature sensor**

The Ex 171-0, in its extremely robust metal housing, guarantees a high measuring accuracy level for long-term measurements in hazardous areas.

The interface to download the data to your PC is attached outside the hazard area. The data is analysed in table or graphics form via easy-to-use software.

Ex 171-0, Temperature data logger, incl. starting magnet, battery and calibration protocol

Part no.

**0577 1730**

- Tamper-proof readings
- Theft-proof mounting
- Large memory for 55,000 readings

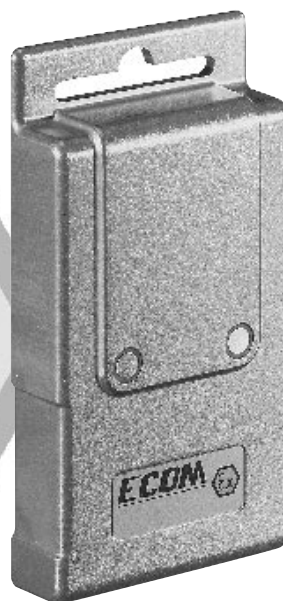

Water-proof, robust metal housing, IP 68



TÜV 00 ATEX 1586

Accessories	Part no.
-------------	----------

Transport and Protection	
--------------------------	--

Transport case (plastic) for measurement data storage instruments (max. 6 off) and accessories, for safe transport. Not for use in Ex-zone	0516 0117
--	-----------

Holder with lock for data logger, theft-proof	0554 1782
---	-----------

Software and accessories (not for use in Ex zone)	
---	--

ComSoft 3 - Professional with data management, incl. database, analysis and graphics function, data analysis, trend curve (not for use in Ex zone)	0554 0830
--	-----------

ComSoft 3 - For requirements to CFR 21 Part 11, incl. database, analysis and graphics function, data analysis, trend curve (w/o interface) (not for use in Ex zone)	0554 0821
---	-----------

Interface, attachable to testostor 171 data logger (not for use in Ex zone)	0554 1781
---	-----------

Ethernet adapter, RS232 - Ethernet incl. software driver, mains unit, facilitates data communication in network (not for use in Ex zone)	0554 1711
--	-----------

Calibration certificates	
--------------------------	--

ISO calibration certificate/temperature, temperature probe; calibration points - 18°C; 0°C; +60°C per channel/instrument	0520 0151
--	-----------

ISO calibration certificate/temperature, temp. data logger; calibration points - 8°C; 0°C; +40°C per channel/instrument	0520 0171
---	-----------

DKD calibration certificate/temperature, Temperature probe; cal. points -20°C; 0°C; +60°C (-4 °F, 92 °F, 140 °F); per channel/instrument	0520 0261
--	-----------

Recommended set	
-----------------	--

Ex 171-0, The Set in the Case	
-------------------------------	--

- Ex 171-0, Temperature data logger, incl. starting magnet, battery and calibration protocol (Part no. 0577 1730)
---

- ComSoft 3 - Professional with data management (Part no. 0554 0830)
--

- Interface, attachable to testostor 171 data logger (Part no. 0554 1781)
---

- Transport case (plastic) for measurement data storage instruments (max. 6 off) and accessories (Part no. 0516 0117)
---

Technical data		
----------------	--	--

Probe type	NTC (internal)	Battery type	Lithium battery
Meas. range	-35 to +70 °C	Dimensions	131 x 68 x 26 mm
Accuracy	±0.5 °C (-35 to +39.9 °C)	Weight	305 g
	±0.6 °C (+40 to +70 °C)	Protection class	IP68
Resolution	0.1 °C	Warranty	2 years
Oper. temp.	-35 to +70 °C	Battery life:	Lithium battery up to 5 years
Storage temp.	-40 to +85 °C	Software:	Menu-driven from Microsoft Windows 95 / ME / 2000 / XP / Vista
Memory	55000		
Material/Housing	Aluminium, anodized		

## testostor 171-1

You can place the testostor 171-1 data logger beside the goods and attach the separate probe to doors or refrigeration appliances up to 12 m away. Air moisture can also be checked, if required.

## Pro data logger with internal temperature sensor and one external temperature probe socket

- Tamperproof measured data
- Data analysis on your PC with user-friendly Windows® software: all measurement and limit values at a glance
- Large memory for up to 55,000 readings



testostor 171-1, temperature data logger with °C/%RH probe connection, incl. starting magnet, battery and calibration protocol

Part no.  
**0577 1715**

(NTC)	Illustration	Meas. range	Accuracy	Reaction time	Part no.
Robust immersion/air probe, quick-action, 6m cable, IP68 probe tip	40 mm Ø 3 mm Conn.: Fixed cable 6 m	-50 to +80 °C	±0.2 °C (-25 to +80 °C) ±0.4 °C (-50 to -25.1 °C)	5 s $t_{90}$ (in water)	0610 1720
Robust, accurate, waterproof food probe (IP65), made of stainless steel	125 mm Ø 4 mm Ø 3 mm Conn.: Fixed cable 2 m	-50 to +120 °C	±0.2 °C (-25 to +80 °C) ±0.4 °C (-50 to -25.1 °C) ±0.5 °C (+80.1 to +120 °C)	10 s $t_{90}$ (in water)	0610 2217
Pipe probe with Velcro, measures flow/return temperature, pipe diameter max. 80 mm	Ø 80 mm Conn.: Fixed cable 3 m	-50 to +80 °C	±0.2 °C (-25 to +80 °C) ±0.4 °C (-50 to -25.1 °C)		0610 4617
Wall surface temperature probe, e.g. provides proof of damage to building material, cable 6.1m long, probe tip 40x15x0.2 mm	Conn.: Fixed cable 6 m	-50 to +120 °C	±0.5 °C (-50 to +120 °C)	20 s $t_{90}$	0628 0007

Humidity/temperature probe	Illustration	Meas. range	Accuracy	t90	Part no.
Humidity/temperature probe with standard plastic protection cap	180 mm Cable/length 3 m Ø 12 mm	0 to +100 %RH -20 to +70 °C	±2 %RH (+2 to +98 %RH) ±0.4 °C (-10 to +50 °C) ±0.5 °C (remaining range)	12 s	0636 9717
Mini humidity/temperature module for measurements at inaccessible points, module cable 1.5m long, probe tip 49x18x7mm	49x18x7 mm Cable/length 1.5 m	0 to +100 %RH -20 to +120 °C	±2 %RH (+2 to +98 %RH) ±0.5 °C (-20 to +120 °C)	20 s	0628 0008



**testostor 171-1**
**Accessories / Technical data**

Accessories	Part no.
<b>Transport and Protection</b>	
Transport case (plastic) for measurement data storage instruments (max. 6 off) and accessories, for safe transport	0516 0117
Holder with lock for data logger, theft-proof	0554 1782
<b>Additional accessories and spare parts</b>	
Spare battery for testostor 171, quick and easy battery replacement	0515 0018
<b>Software and accessories</b>	
ComSoft 3 - Professional with data management, incl. database, analysis and graphics function, data analysis, trend curve	0554 0830
ComSoft 3 - For requirements to CFR 21 Part 11, incl. database, analysis and graphics function, data analysis, trend curve (w/o interface)	0554 0821
Interface, attachable to testostor 171 data logger	0554 1781
Ethernet adapter, RS232 - Ethernet incl. software driver, mains unit, facilitates data communication in network	0554 1711
<b>Calibration certificates</b>	
ISO calibration cert./temperature, temperature data logger; calibration points selectable from -196 to +1260°C	0520 0141
ISO calibration certificate/temperature, temp. data logger; calibration points -8°C; 0°C; +40°C per channel/instrument	0520 0171
DKD calibration certificate/temperature, data logger, transmitter, probe without display; cal. points freely selectable from -196 to +1000°C	0520 0281
ISO calibration certificate humidity, Calibration points 11.3 %RH and 75.3 %RH at +25°C	0520 0006
ISO calibration certificate humidity, Humidity data logger; calibration points 11.3 %RH and 75.3 %RH at +25 °C/+77 °F; per channel/instrument	0520 0076
DKD calibration certificate/humidity, electronic hygrometers; calibration points 11.3%RH and 75.3%RH at +25°C	0520 0206
DKD calibration cert./humidity, humidity data logger; cal. points 11.3%RH and 75.3%RH at +25°C; per channel/instrument	0520 0246

Recommended set
<b>testostor 171-1, Standard set</b>
<ul style="list-style-type: none"> <li>- testostor 171-1, temperature data logger with °C/%RH probe connection, incl. starting magnet, battery and calibration protocol (Part no. 0577 1715)</li> <li>- Robust immersion/air probe, quick-action, 6m cable, IP68 probe tip (Part no. 0610 1720)</li> <li>- ComSoft 3 - Professional with data management (Part no. 0554 0830)</li> <li>- Interface, attachable to testostor 171 data logger (Part no. 0554 1781)</li> <li>- Transport case (plastic) for measurement data storage instruments (max. 6 off) and accessories (Part no. 0516 0117)</li> </ul>

Technical data			
Probe type	NTC (external)	NTC (internal)	Testo humid. sensor, cap.
Meas. range	-50 to +120 °C	-35 to +70 °C	0 to +100 %RH
Accuracy ±1 digit	±0.2 °C (-34.9 to +39.9 °C) ±0.4 °C (+40 to +120 °C) ±0.6 °C (-50 to -35 °C)	±0.2 °C (-35 to +39.9 °C) ±0.4 °C (+40 to +70 °C)	±2 %RH (+2 to +98 %RH)
Resolution	0.1 °C	0.1 °C	0.1 %RH
Oper. temp.	-35 to +70 °C	Dimensions 131 x 68 x 26 mm	
Storage temp.	-40 to +85 °C	Warranty 2 years	
Battery type	Lithium battery	Meas. rate: 2 s to 24 h, selectable	
Material/Housing	Aluminium, anodized	Battery life: up to 5 years with lithium battery	
Protection class	IP65	Software: menu-driven from Microsoft Windows 95 / ME / 2000 / XP / Vista	
Memory	55000		
Weight	305 g		

## testostor 171-4

## Pro data logger with 4 external temperature probe sockets

testostor 171-4 with up to 4 external temperature probes is used for simultaneous temperature recording at different locations e.g. in production processes or in storage areas.

- Tamperproof measured data
- Data analysis on your PC with user-friendly Windows® software: all measurement and limit values at a glance
- Large memory for up to 55,000 readings
- With calibration protocol



testostor 171-4, temperature data logger, 4 channels, with starting magnet, battery and calibration protocol

Part no.  
**0577 1714**

Probes (NTC)	Illustration	Meas. range	Accuracy	Reaction time	Part no.
Robust immersion/air probe, quick-action, 6m cable, IP68 probe tip	<p>40 mm Ø 3 mm Conn.: Fixed cable 6 m</p>	-50 to +80 °C	±0.2 °C (-25 to +80 °C) ±0.4 °C (-50 to -25.1 °C)	5 s $t_{90}$ (in water)	0610 1720
Robust, accurate, waterproof food probe (IP65), made of stainless steel	<p>125 mm Ø 4 mm Ø 3 mm Conn.: Fixed cable 2 m</p>	-50 to +120 °C	±0.2 °C (-25 to +80 °C) ±0.4 °C (-50 to -25.1 °C) ±0.5 °C (+80.1 to +120 °C)	10 s $t_{90}$ (in water)	0610 2217
Pipe probe with Velcro, measures flow/return temperature, pipe diameter max. 80 mm	<p>Ø 80 mm 30 mm Conn.: Fixed cable 3 m</p>	-50 to +80 °C	±0.2 °C (-25 to +80 °C) ±0.4 °C (-50 to -25.1 °C)		0610 4617
Wall surface temperature probe, e.g. provides proof of damage to building material, cable 6.1m long, probe tip 40x15x0.2 mm	<p>Conn.: Fixed cable 6 m</p>	-50 to +120 °C	±0.5 °C (-50 to +120 °C)	20 s $t_{90}$	0628 0007

**testostor 171-4**
**Accessories / Technical data**

Accessories	Part no.
<b>Transport and Protection</b>	
Transport case (plastic) for measurement data storage instruments (max. 6 off) and accessories, for safe transport	0516 0117
Holder with lock for data logger, theft-proof	0554 1782
<b>Additional accessories and spare parts</b>	
Spare battery for testostor 171, quick and easy battery replacement	0515 0018
<b>Software and accessories</b>	
ComSoft 3 - Professional with data management, incl. database, analysis and graphics function, data analysis, trend curve	0554 0830
ComSoft 3 - For requirements to CFR 21 Part 11, incl. database, analysis and graphics function, data analysis, trend curve (w/o interface)	0554 0821
Interface, attachable to testostor 171 data logger	0554 1781
Ethernet adapter, RS232 - Ethernet incl. software driver, mains unit, facilitates data communication in network	0554 1711
<b>Calibration certificates</b>	
ISO calibration cert./temperature, temperature data logger; calibration points selectable from -196 to +1260°C	0520 0141
ISO calibration certificate/temperature, temp. data logger; calibration points - 8°C; 0°C; +40°C per channel/instrument	0520 0171
DKD calibration certificate/temperature, data logger, transmitter, probe without display; cal. points freely selectable from -196 to +1000°C	0520 0281

Recommended set
<b>testostor 171-4, 4 x temperature measurement at different locations</b>
- testostor 171-4, temperature data logger, 4 channels, with starting magnet, battery and calibration protocol (Part no. 0577 1714)
- 4 x Robust immersion/air probe, quick-action, 6m cable, IP68 probe tip (Part no. 0610 1720)
- ComSoft 3 - Professional with data management (Part no. 0554 0830)
- Interface, attachable to testostor 171 data logger (Part no. 0554 1781)
- Transport case (plastic) for measurement data storage instruments (max. 6 off) and accessories (Part no. 0516 0117)

Technical data		Material/Housing	Aluminium, anodized
<b>Probe type</b>	<b>NTC external</b>	Protection class	IP65
Meas. range	-50 to +120 °C	Memory	55000
Accuracy	±0.2 °C (-34.9 to +39.9 °C)	Weight	305 g
±1 digit	±0.4 °C (+40 to +120 °C) ±0.6 °C (-50 to -35 °C)	Dimensions	131 x 68 x 26 mm
Resolution	0.1 °C	Warranty	2 years
Oper. temp.	-35 to +70 °C	Measuring rate: 2 s to 24 h, selectable	
Storage temp.	-40 to +85 °C	Battery life: Lithium battery up to 5 years	
Battery type	Lithium battery	Software: menu-driven from Microsoft Windows 95 / NT 4 Servicepack 4 / ME / 2000 / XP / Vista	

## testostor 171-8

testostor 171-8, a compact data logger with 4 external thermocouple connections. The data logger is equipped for two different types of thermocouple:

- Type K (NiCr-Ni), quick-action probes for measurements from -200 to +1000°C

- Type T (Cu-CuNi), fast, accurate probes for measurements from -50 to +350°C

testostor 171-8, temperature data logger, 4 channels, with starting magnet, battery and calibration protocol

Part no.  
**0577 1718**

## Pro data logger with 4 external temperature probe sockets for high temperatures

- On-site application: Testo software for Palm OS® replaces laptop/PC
- Connection to all Testo thermocouple probes (Type K/T) possible with thermocouple plug
- Large memory for up to 55,000 readings

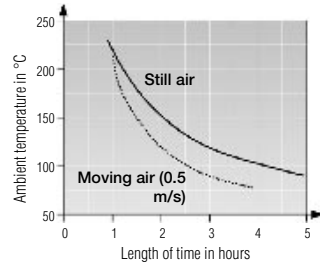

The diagram shows how long testostor 171-8 in a heat-proof case can be subjected to a certain ambient temperature before the maximum inner temperature of +70 °C is reached.



Heat-proof case made of solid aluminium housing protects data logger (optional). When the heat-proof case is used, the data logger can handle processes with an operating temperature of up to +200°C.

Probes	Illustration	Meas. range	Accuracy	t99	Part no.
Pipe wrap probe for pipe diameter 5 to 65 mm, with exchangeable measuring head. Meas. range short-term up to +280°C, TC Type K	Conn.: Fixed cable	-60 to +130 °C	Class 2*	5 s	0602 4592
Spare meas. head for pipe wrap probe, TC Type K	35 mm 15 mm	-60 to +130 °C	Class 2*	5 s	0602 0092
Clamp probe for measurements on pipes, pipe diameter 15 to 25 mm (max. 1"), meas. range short-term up to +130°C, TC Type K	Conn.: Fixed cable	-50 to +100 °C	Class 2*	5 s	0602 4692
Magnetic probe, adhesive force approx. 20 N, with magnets, for measurements on metal surfaces, TC Type K	35 mm Ø 20 mm Conn.: Fixed cable	-50 to +170 °C	Class 2*	150 s	0602 4792
Magnetic probe, adhesive force approx. 10 N, with magnets, for higher temp., for measurements on metal surfaces, TC Type K	75 mm Ø 21 mm Conn.: Fixed cable	-50 to +400 °C	Class 2*		0602 4892
Immersion tip, flexible, TC Type K	500 mm Ø 1.5 mm	-200 to +1000 °C	Class 1*	5 s	0602 5792
Thermocouple with TC adapter, flexible, 800mm long, fibre glass, TC Type K	800 mm Ø 1.5 mm	-50 to +400 °C	Class 2*	5 s	0602 0644
Thermocouple with TC adapter, flexible, 1500mm long, fibre glass, TC Type K	1500 mm Ø 1.5 mm	-50 to +400 °C	Class 2*	5 s	0602 0645
Thermocouple with TC adapter, flexible, 1500mm long, Teflon, TC Type K	1500 mm Ø 1.5 mm	-50 to +250 °C	Class 2*	5 s	0602 0646

\*According to standard EN 60584-2, the accuracy of Class 1 refers to -40 to +1000 °C (Type K), Class 2 to -40 to +1200 °C (Type K), Class 3 to -200 to +40 °C (Type K).

Connection to all Testo thermocouple probes (Type K/T) possible with thermocouple plug

**testostor 171-8**
**Accessories / Technical data**

Accessories	Part no.
<b>Transport and Protection</b>	
Heat-proof case with heat-proof insert, rubber seal, 4 clamp screw connections for thermocouples with diameter of 1.5 mm, protects testostor 171-8 from hot environment, dimensions 260 x 160 x 90 mm	0553 1701
Transport case (plastic) for measurement data storage instruments (max. 6 off) and accessories, for safe transport	0516 0117
Holder with lock for data logger, theft-proof	0554 1782
Extension cable, 5m, for thermocouple probe Type K	0554 0592
<b>Additional accessories and spare parts</b>	
Spare battery for testostor 171, quick and easy battery replacement	0515 0018
<b>Software and accessories</b>	
ComSoft 3 - Professional with data management, incl. database, analysis and graphics function, data analysis, trend curve	0554 0830
ComSoft 3 - For requirements to CFR 21 Part 11, incl. database, analysis and graphics function, data analysis, trend curve (w/o interface)	0554 0821
Interface, attachable to testostor 171 data logger	0554 1781
Ethernet adapter, RS232 - Ethernet incl. software driver, mains unit, facilitates data communication in network	0554 1711
<b>Calibration certificates</b>	
ISO calibration cert./temperature, temperature data logger; calibration points selectable from -196 to +1260°C	0520 0141
ISO calibration certificate/temperature, temp. data logger; calibration points -8°C; 0°C; +40°C per channel/instrument	0520 0171
DKD calibration certificate/temperature, data logger, transmitter, probe without display; cal. points freely selectable from -196 to +1000°C	0520 0281

Recommended set
<b>testostor 171-8, Food set</b>
<ul style="list-style-type: none"> <li>- testostor 171-8, temperature data logger, 4 channels, with starting magnet, battery and calibration protocol (Part no. 0577 1718)</li> <li>- 4 x Immersion tip, flexible, TC Type K (Part no. 0602 5792)</li> <li>- ComSoft 3 - Professional with data management (Part no. 0554 0830)</li> <li>- Interface, attachable to testostor 171 data logger (Part no. 0554 1781)</li> <li>- Transport case (plastic) for measurement data storage instruments (max. 6 off) and accessories (Part no. 0516 0117)</li> </ul>

Technical data		
Probe type	Type K (NiCr-Ni)	Type T (Cu-CuNi)
Meas. range	-200 to +1000 °C	-50 to +350 °C
Accuracy ±1 digit	±(0.4 °C ±0.2% of mv)	±(0.4 °C ±0.2% of mv)
Resolution	0.1 °C (-200 to +249.9 °C) 1 °C (+250 to +1000 °C)	0.1 °C (-50 to +249.9 °C) 1 °C (+250 to +350 °C)

Oper. temp.	0 to +70 °C	Dimensions	131 x 68 x 26 mm
Storage temp.	-40 to +85 °C	Warranty	2 years
Battery type	Lithium battery	Measuring rate:	2s to 24h, selectable
Material/Housing	Aluminium, anodized	Battery life:	up to 5 years
Protection class	IP42	Software:	Menu-driven from Microsoft Windows 95 / NT 4 Servicepack 4 / ME / 2000 / XP / Vista
Memory	55000		
Weight	305 g		

Heat-proof case							
When the heat-proof case is used, the data logger can handle processes with an operating temperature of up to +200°C	<table border="1"> <tbody> <tr> <td>Dimensions</td> <td>260 x 160 x 90 mm</td> </tr> <tr> <td>Material/Housing</td> <td>Aluminium, anodized</td> </tr> <tr> <td>Warranty</td> <td>2 years</td> </tr> </tbody> </table>	Dimensions	260 x 160 x 90 mm	Material/Housing	Aluminium, anodized	Warranty	2 years
Dimensions	260 x 160 x 90 mm						
Material/Housing	Aluminium, anodized						
Warranty	2 years						

## testo 575

## Fast-action printer and logger control in one for testo 175/177

testo 575 is the practical fast-action printer for all testo 175 and 177 data loggers. It can be set to your language. In addition to being a practical printer, testo 575 can also be used as a logger control unit.

Fast testo 575 printer, incl. 1 roll of thermal paper and batteries

Part no.  
**0554 1775**

### Print functions

- Fast-action print mechanism, 6 lines/s
- Prints tables/graphics
- Brief info. or full memory can be printed as required
- Determine section to be printed
- Your language can be set
- Self-adhesive Testo paper can also be used

### Control functions

- Stops testo 175/177 loggers
- Reboots logger with saved parameters (reprogramming)
- Both buttons can be blocked by PC software



### Technical data

Printer: Infrared thermal line printer with graphics function  
 Contrast: Can be adjusted  
 Paper width: 56 mm  
 Roll diameter: Up to 35 mm  
 Paper: Standard paper and two-layer adhesive  
 Number of characters per line: 24  
 Graphics resolution: 203 dpi  
 Operating temp.: -5 to +50°C (for 5 min at -

30°C)  
 Storage temperature: -30 to +70°C  
 Power: 6x round cell 1AA  
 Battery life: Up to 40,000 print lines  
 Battery change: By user  
 Housing: ABS (black), with "Soft-Protect" inserts

### Accessories

Accessories	Part no.
Spare thermal paper for printer (6 rolls)	0554 0569
Spare thermal paper for printer (6 rolls), measurement data documentation legible for up to 10 years	0554 0568
Label thermal paper (Testo patent) for testo 575 printer (6 rolls), can be applied directly	0554 0561

**testo 580**
**Compact data collector for testo 175/177 for on-site readout**

The testo 580 data collector collects data on site for upload to PC and analysis

- Can read out up to 25 full testo 175 loggers or 10 full testo 177 loggers
- Displays all status information
- Download collected data to PC using Testo ComSoft 3



testo 580 data collector set with RS232, readout holders included, for testo 175/177 data loggers

Part no.  
**0554 1778**

testo 580 data collector set with USB, readout holders included, for testo 175/177 data loggers

Part no.  
**0554 1764**

**Control functions**

- Stops logger
- Reboots logger
- Both control functions can be blocked via PC

**Technical data**

Memory capacity: 1 MB (approx. 500,000 values)
Read out time in logger: Approx. 400 readings/s
Read out time in PC: Approx. 1,500 readings/s
Logger interface: Infrared transfer, bidirectional
PC interface: RS232 (Sub_D socket) or USB
Operating temperature: -30 to +70°C
Storage temperature: -40 to +85°C
On/Off switch: Off: AutoOFF to 1 min

**Functions**

Display: Logger memory used, testo 580 memory used, logger battery life, testo 580 battery life, data transfer in progress, data transfer ok or defective, wraparound display

Other: Data secure even if battery is spent

Power: 3x micro AAA cells

Housing: ABS (black)

**testo 581**
**Alarm limit signal output for testo 175/177 to forward alarm messages**

The alarm signal output testo 581 makes it possible to send alarm messages to external components, e.g.: horns, lamps, PLC.

External components are connected via a terminal strip in the battery compartment of testo 581, the signal is transferred via the floating signal output. This can be set as an NC or NO contact.

**Alarm is triggered when:**

- Programmed limit values in the data logger are exceeded
- Logger is stopped due to spent battery
- Probe is disconnected
- Alarm unit battery is spent

**The control functions**

You will be informed directly at the touch of a button, if the alarm has already been triggered. The alarm of the external components, e.g. the horn, can be reset using the reset button.



testo 581 alarm signal output, floating, for testo 175/177

Part no.  
**0554 1769**

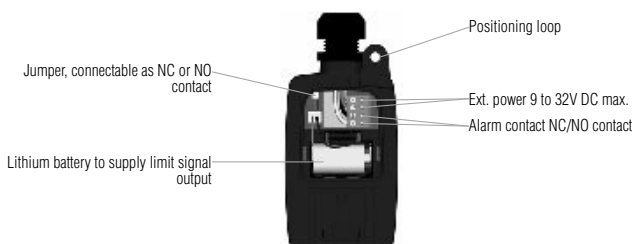
**Connection assignment (back of limit signal output)**

testo 581 can be used together with all testo 175/177 data loggers. Once connected to the data logger wall holder, communication between testo 175/177 and the limit signal output takes place via the infrared interface.

**Technical data**

Signal	Floating signal output, can be set as NC or NO contact
No./switch. chann.	1 channel
Power limit signal output	Battery (Included) or 9 to 32V DC max. (external)
Max. switching voltage	60V DC/25V AC (SELV/PELV switch circuits)
Max. duration switch-off current	1A DC/AC
Max. switch power	30W/30VA
Conn.	Via terminal strip in battery compartment (output and power)
Oper. temp.	-40 to +70 °C
Storage temp.	-40 to +85 °C
Battery type	Lithium (1/2 AA)
Battery life	Approx. 5 years
Material/Housing	Polycarbonate (black)
Dimensions	82 x 52 x 30 mm
Protection class	IP68

## ComSoft 3 - Basic

The Basic version has all the functions needed to monitor, analyse, save and print data. The dataloggers are programmed and read out using the instrument drivers supplied. The limit values to be monitored can be defined as required; short titles, text fields and channel names ensure clear allocation if several loggers are in use.

Once read out, data can be shown in table or line graphics and then analysed.

The recipient's e-mail address can be entered when programming so that data can be easily forwarded through your locally installed e-mail program by simply clicking on "Send...". The saved e-mail address is then entered in the address box.

## User-friendly operation and convenient analysis

### Additional functions:

- Axes can be scaled as required
- Frequently used scales can be saved for future use
- Min/Max and mean calculation in tables
- Printout as table or graphic on all printers compatible with Windows
- Data export to other applications via clipboard
- Automatic search for instrument driver during initial operation (Autodetect)
- Crosshair function, fast scanning in graphics with direct value display

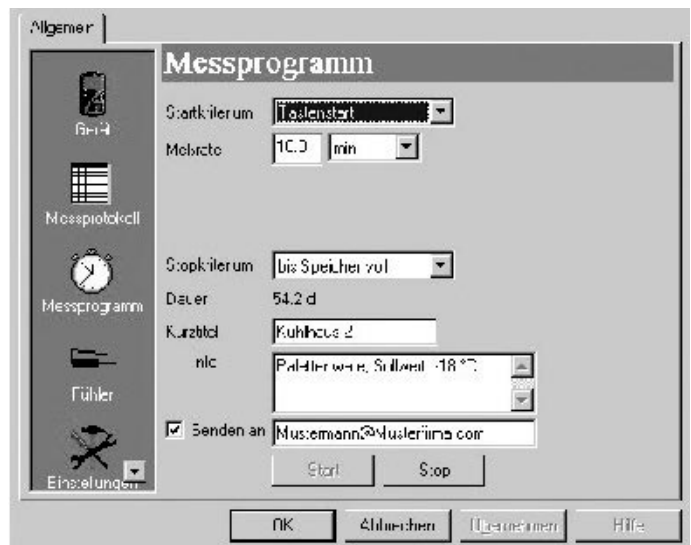

Programming the logger

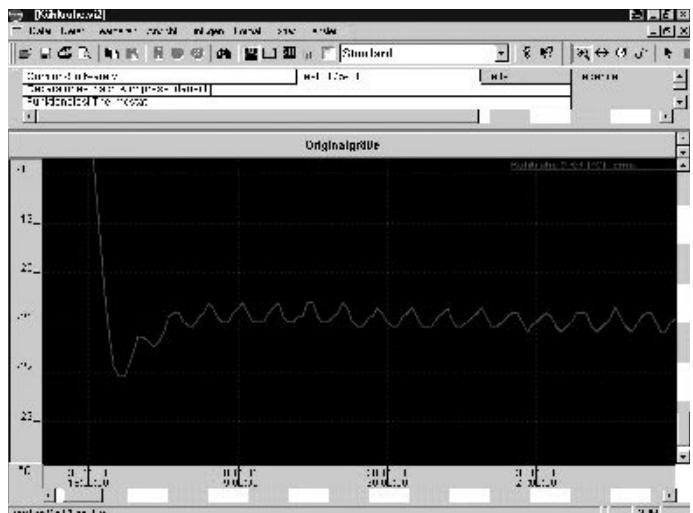

Analysing measurement data

Kühlhaus 2	Datum	Uhrzeit	PCI Kanal 1
1	13.12.12	16:45:57	23,2
2	13.12.12	16:55:52	23,1
3	13.12.12	17:05:52	23,1
4	13.12.12	17:15:52	22,0
5	13.12.12	17:25:52	22,9
6	13.12.12	17:35:52	22,8
7	13.12.12	17:45:52	22,9
8	13.12.12	17:55:52	22,9

Table view/Documentation

### Comsoft 3 -Basic for:

- Data loggers from the testo 175 and testo 177 series

### testo 175

#### ComSoft 3 - Basic Set with RS232 interface for testo 175

Basic software with diagram and table function, incl. desk-top holder, PC connection cable

Part no.

**0554 1759**

#### ComSoft 3 - Basic Set with USB interface for testo 175

Basic software with diagram and table function, incl. desk-top holders, PC connection cable

Part no.

**0554 1766**

### testo 177

#### ComSoft 3 - Basic Set with RS 232 interface for testo 177

Basic software with diagram and table function, incl. desk-top holder, PC connection cable

Part no.

**0554 1774**

#### ComSoft 3 - Basic Set with USB interface for testo 177

Basic software with diagram and table function, incl. desk-top holders, PC connection cable

Part no.

**0554 1767**



## ComSoft 3 - Professional

In addition to all the functions of the Basic version, the Professional also has extra display options (e.g. digit box, bar chart, analog instrument, xy plot) and **convenient data filing**. Measurement data can be stored in their own folders so that, for example, several data loggers from different locations can be organised in a tree structure. It is particularly recommended for instruments, which can manage many measurement logs e.g. the testo 580 data collector. The driver in this instrument is set up such that the directory structure of the Professional software is supported. The result is clear and comprehensible data handling.

### ComSoft 3 - Professional with data management

incl. database, analysis and graphics function, data analysis, trend curve

Part no.

**0554 0830**

## Professional Software including Data Filing

### Additional functions:

- Adapt menus and range of functions
- Select different print heads when printing tables and graphics
- Extended display options such as digit box, bar chart, analog instrument and xy plot
- Input of mathematical functions with calculation on a new measurement channel
- Compensation functions 0 (mean) to 7th degree
- Developer ToolBox with functions for integrating the instrument driver in non-Testo software

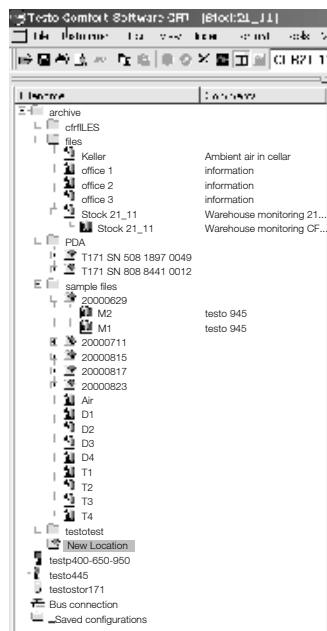

Structured filing of measured data and parameters in folders, locations, logs and channels

### Comsoft 3 -Professional for:

- Data loggers from the testo 175, testo 177 and testostor 171 series
- Reference measuring instrument testo 950

Accessories	Part no.
RS232 interface for testo 175/177 incl. desk-top holders, PC connection cable, (please also order for ComSoft 3 - Professional)	0554 1757
USB interface, for testo 175/177 incl. desk-top holders, PC conn. cable, (Please order with ComSoft 3 - Professional)	0554 1768
Interface, attachable to testostor 171 data logger	0554 1781

## CFR 21 Part 11

A validation-compatible ComSoft 3.3 Version 21 CFR 11 has been developed especially for the management and filing of process data. All FDA requirements can be fulfilled if used as part of a cohesive system:

### ComSoft 3 - For requirements to CFR 21 Part 11

incl. database, analysis and graphics function, data analysis, trend curve (w/o interface)

Part no.

**0554 0821**

## Software for requirements in accordance with CFR 21 Part 11

proof totals

- Inactivity lockout to prevent unauthorised access
- Monitors logins and logouts, successful/failed use of digital signatures and modification of raw data with the aid of Audit Trail
- Complete integration in the Windows 2000 security system (certificates, rights management, user and password management, user authentication)
- Option of data export in generally readable PDF file format e.g. to send to the FDA validation point responsible or to display during a company audit.

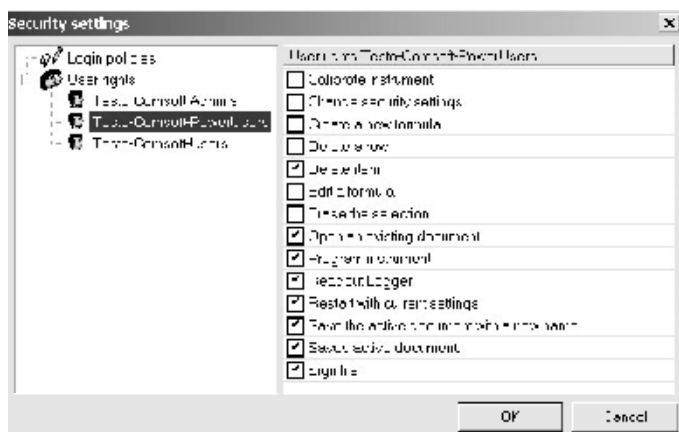

User management in groups



Display: Limit value violation in table format

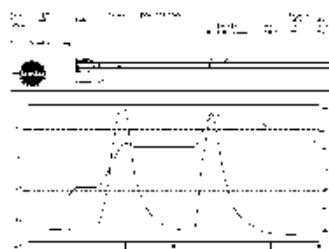

Graphic display of readings

### CFR21 Part 11 for:

- Data loggers from the testo 175, testo 177 and testostor 171 series
- Reference measuring instrument testo 950

## Ethernet adapter

### The new Ethernet adapter facilitates:

- Measurements on site, e.g. production, warehouses, incoming goods
- Measuring instrument remains on site, transport not necessary
- Data can be checked from office
- Centralised data filing

### Ethernet offers:

- Fast transfer of readings
- Use of an existing network without additional cabling
- Long transmission paths
- Identification of measuring instruments in system network

**Ethernet adapter, RS232 - Ethernet incl. software driver, mains unit facilitates data communication in network (not for use in Ex-zone)**

Part no.

**0554 1711**

## Access Ethernet with Testo measuring instruments

### Long-term monitoring of climate data

The parameters temperature and humidity are logged and saved on site by the data logger. Using the Ethernet adapter, measurement data saved in the logger can be read out and filed via the PC network. The data is easily analysed and checked on the PC in your office. The Ethernet adapter has the following benefits:

- Affordable handling since it is not necessary to read the data on site or to take the logger into the office
- Short access times because you can quickly access current measurement data at any time.



### Multi-point checks on site

Spot checks are carried out on site in production halls or in incoming goods departments using Testo handheld measuring instruments. The measurement data can be sent immediately to a central office via the Ethernet adapter. This facilitates fast reaction times if further actions are required.

Accessories	Part no.
<b>System accessories: testo 950</b>	
ComSoft 3 - Professional with data management, incl. database, analysis and graphics function, data analysis, trend curve	0554 0830
RS232 cable, connects instrument to PC (1.8 m) for data transfer	0409 0178
<b>System accessories: testo 175, testo 177</b>	
ComSoft 3 - Professional with data management, incl. database, analysis and graphics function, data analysis, trend curve	0554 0830
RS232 interface for testo 175/177 incl. desk-top holders, PC connection cable, (please also order for ComSoft 3 - Professional)	0554 1757
<b>System accessories: testo 171</b>	
ComSoft 3 - Professional with data management, incl. database, analysis and graphics function, data analysis, trend curve	0554 0830
Interface, attachable to testostor 171 data logger	0554 1781

Technical data		Management and software config.	Internet Browser e.g. from Netscape or Microsoft Telnet
Dimensions	45 x 48 x 14 mm	Interface	Serial interface on computer board with terminal program
Oper. temp.	+0 to +70 °C		
Software	Microsoft Windows 2000 / NT 4.0 / ME / 98 / 95	Provision of a local virtual COM port (Windows systems)	
Power supply	Mains unit, 5 Volt app. 230 mA		
Humidity class	F to DIN 40040		
EMC	Radio interference/Fault free op.		
Interface	25 pin RS 232 connection with adapter 25/9pin		
Logs	TCP/IP, LPR, Telnet, SNMP, DHCP DDNS, ARP, BOOTP, ICMP		



## Stationary temperature probes

Testo has been offering stationary temperature probes for over 20 years, not only as standard probes, but also as customized probes. A overview of the standard probes is given on the following pages. Details of the temperature probes can be found on the internet at [www.testo-celcius.com](http://www.testo-celcius.com) or in the brochure "Stationary Measurement Solutions for Air Conditioning and Process"

## Overview standard probes



in air



in gases

non-corrosive gases

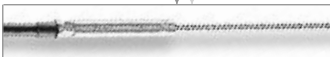

**Type 04**  
Process temperature probe, fixed line connection, very small probe shaft diameter possible.



**Type 23**  
Air duct temperature probe



**Type 09**  
Sheathed thermocouple probe, with TC connector for extremely rapid temperature recording. Probe material Inconel

corrosive media



**Type 11**  
Robust process temperature probe. Connected via plug-in connection (connector Tmax 80 °C)



**Type 24**  
Cold store and storage room temperature probe, with terminals in IP65 housing



**Type 10**  
Robust process temperature probe with precision coupling (Tmax. 200 °C).

corrosive media



**Type 20**  
Ambient temperature probe, plastic housing (also available with integrated transmitter)

## Stationary temperature probes

## Overview standard probes



in liquids



on surfaces

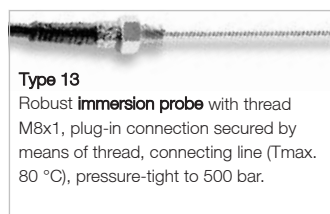
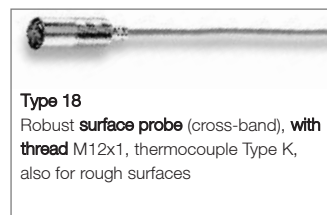
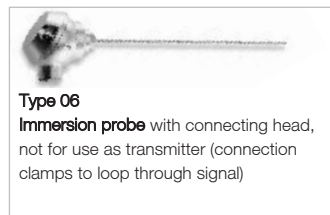
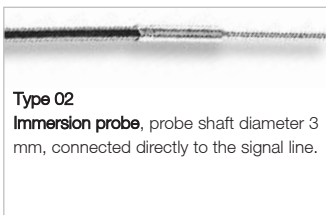
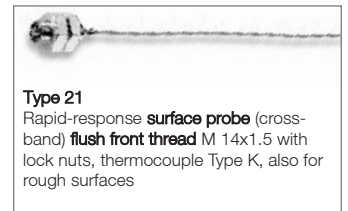
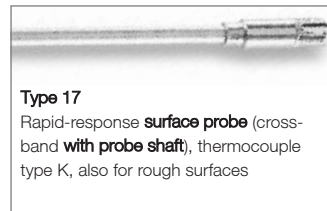
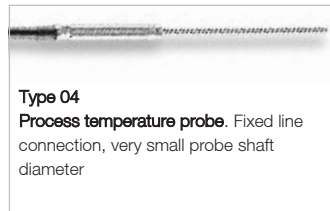
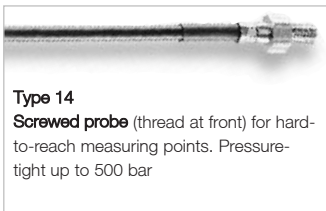
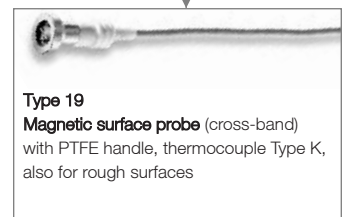
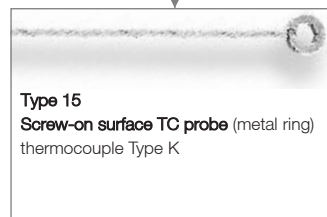
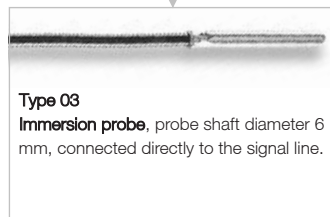
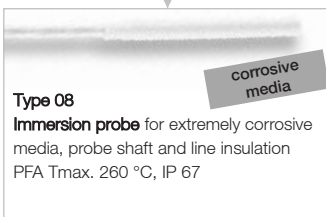

## Configurator "Testo Celsius" on the internet

Temperature probes often have to be obtained at short notice: A system is at a stillstand and requires a replacement probe. Or a "second source" needs to be found for a new type of machine.

Finding the right probe which meets the requirements of the process quickly and easily, is in most cases difficult because of the large variety of types. Specialized knowledge of measurement technology is often a prerequisite for being able to select the right probe.

### Clear specifications in a few clicks of the mouse

The selection assistance "Testo Celsius" on the Testo homepage solves this problem in a very customer-friendly way. The user is guided through the selection possibilities with simple questions.

After selecting the probe, the user can send the probe very directly to Testo Sales by e-mail. In addition to this, after selecting the temperature probe, a suitable temperature measurement transmitter (testo 55) or display (testo 54) can also be found..

The configurator is to be found under [www.testo-celsius.com](http://www.testo-celsius.com)

Just click in !

## Temperature probe selection made easy

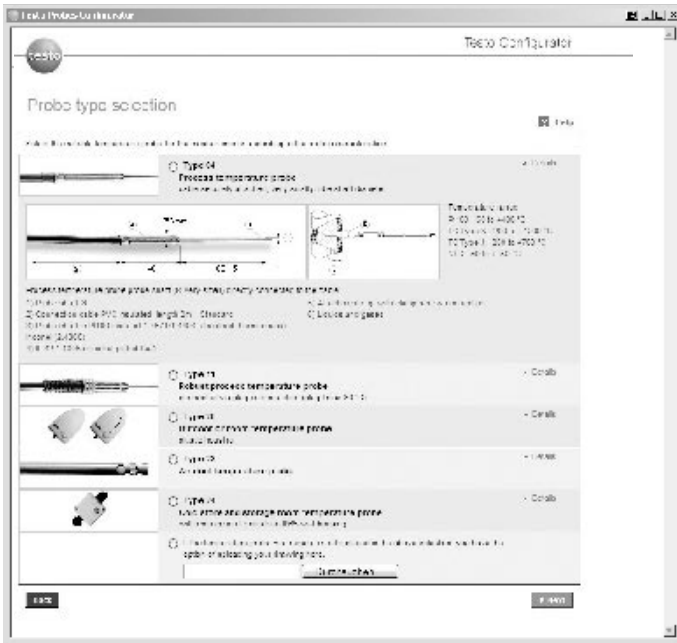

Can't find the right sensor for your application?  
Configure your individual temperature probe!

Radio range up to 20 metres  
(without obstruction)

**Radio module**



Upgrading the measuring instrument with radio option. Simply plug into the instrument.

Radio temperature probes can be connected to the following measuring instruments:  
testo 110  
testo 926  
testo 925  
testo 922  
testo 735



**B Radio probe for immersion/penetration measurements**



Affordable NTC radio probe for immersion/penetration measurements

**C Radio handle with special probe heads**



The radio handle is simply fitted with exchangeable probe heads. Two special T/C probe heads for air/immersion/penetration and surface measurements are available.

**D Radio handle with T/C adapter for conventional T/C probes**

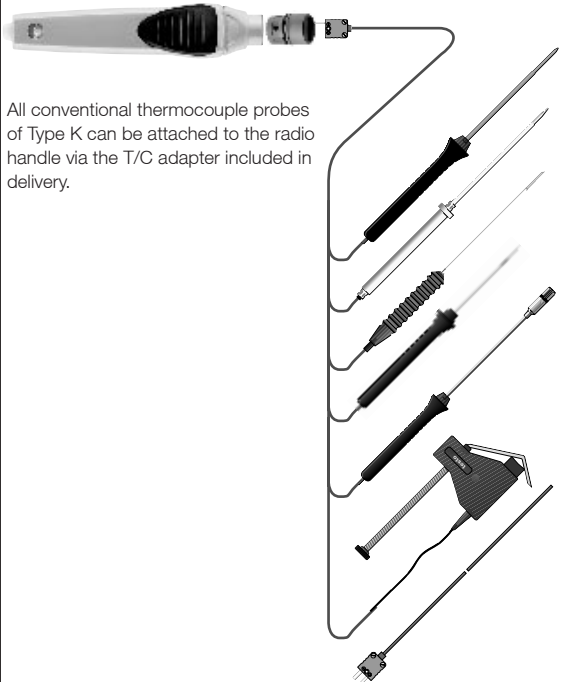

All conventional thermocouple probes of Type K can be attached to the radio handle via the T/C adapter included in delivery.

**Versatility through radio probes**

In addition to conventional probes with cable attached, the new Compact and Professional Line instruments can also communicate optionally with radio probes, i.e. readings are transmitted wirelessly from the radio probe to a measuring instrument. The distance between measuring instrument and measurement location can be up to 20 metres. Awkward probe cables are therefore a thing of the past.

Data is transmitted from the probe to the measuring instrument via the radio module plugged into the instrument. Up to three radio probes can communicate with the instrument. The measuring rate is selectable (0.5 s or 10 s), the setting is made directly in the handle. The probe battery life is 2 months when used in continuous measurement.





**Option: Radio**
**Ordering data**

<b>A Radio module for upgrading measuring instrument with radio option</b>		
Country versions	Radio freq.	Part no.
Radio module for measuring instrument, 869.85 MHz, approval for the countries: DE, FR, UK, BE, NL, ES, IT, SE, AT, DK, FI, HU, CZ, PL, GR, CH, PT, SI, MT, CY, SK, LU, EE, LT, IE, LV, NO	869.85 MHz FSK	0554 0188
Radio module for measuring instrument, 915.00 MHz FSK, approval for USA, CA, CL	915.00 MHz FSK	0554 0190

<b>B Radio probes for immersion/penetration measurements</b>					
Radio immersion/penetration probes	Meas. range	Accuracy	Resolution	$t_{99}$	
<b>Radio immersion/penetration probe, NTC</b> 	-50 to +275 °C	$\pm 0.5$ °C (-20 to +80 °C) $\pm 0.8$ °C (-50 to -20.1 °C) $\pm 0.8$ °C (+80.1 to +200 °C) $\pm 1.5$ °C (remaining range)	0.1 °C	$t_{99}$ (in water) 12 s	
Country versions	Radio freq.	Part no.			
Radio immersion/penetration probe, NTC, approval for the countries: DE, FR, UK, BE, NL, ES, IT, SE, AT, DK, FI, HU, CZ, PL, GR, CH, PT, SI, MT, CY, SK, LU, EE, LT, IE, LV, NO	869.85 MHz FSK	0613 1001			
Radio immersion/penetration probe, NTC, approval for USA, CA, CL	915.00 MHz FSK	0613 1002			

<b>C Assembled for you: Radio handles with probe head</b>					
Radio handles with probe head for air-/ immersion-penetration-meas.	Meas. range	Accuracy	Resolution	$t_{99}$	
<b>Radio handle for attachable probe heads with T/C probe head for air and immersion/penetration measurement</b> 	-50 to +350 °C Short-term to +500 °C	Radio handle: $\pm (0.5$ °C +0.3% of mv) (-40 to +500 °C) $\pm (0.7$ °C +0.5% of mv) (remaining range) T/C probe head: Class 2	0.1 °C (-50 to +199.9 °C) 1.0 °C (remaining range)	$t_{99}$ (in water) 10 s	
Country versions	Radio freq.	Part no.			
Radio handle for plug-in probe heads, incl. T/C adapter, approval for the countries: DE, FR, UK, BE, NL, ES, IT, SE, AT, DK, FI, HU, CZ, PL, GR, CH, PT, SI, MT, CY, SK, LU, EE, LT, IE, LV, NO	869.85 MHz FSK	0554 0189			
T/C probe head for air/immersion/penetration measurement, attachable to radio handle, T/C Type K		0602 0293			
Radio handle for plug-in probe heads, incl. T/C adapter, approval for USA, CA, CL	915.00 MHz FSK	0554 0191			
T/C probe head for air/immersion/penetration measurement, attachable to radio handle, T/C Type K		0602 0293			

Radio handles with probe head for surface measurement	Meas. range	Accuracy	Resolution	$t_{99}$	
<b>Radio handle for attachable probe heads with T/C probe head for surface measurement</b> 	-50 to +350 °C Short-term to +500 °C	Radio handle: $\pm (0.5$ °C +0.3% of mv) (-40 to +500 °C) $\pm (0.7$ °C +0.5% of mv) (remaining range) T/C probe head: Class 2	0.1 °C (-50 to +199.9 °C) 1.0 °C (remaining range)	5 s	
Country versions	Radio freq.	Part no.			
Radio handle for plug-in probe heads, incl. T/C adapter, approval for the countries: DE, FR, UK, BE, NL, ES, IT, SE, AT, DK, FI, HU, CZ, PL, GR, CH, PT, SI, MT, CY, SK, LU, EE, LT, IE, LV, NO	869.85 MHz FSK	0554 0189			
T/C probe head for surface measurement, attachable to radio handle, T/C Type K		0602 0394			
Radio handle for plug-in probe heads, incl. T/C adapter, approval for USA, CA, CL	915.00 MHz FSK	0554 0191			
T/C probe head for surface measurement, attachable to radio handle, T/C Type K		0602 0394			

<b>D Radio handles, separate</b>					
Radio handles for attachable T/C probes	Meas. range	Accuracy	Resolution		
Radio handle for attachable probe heads incl. adapter for attaching T/C probes (Type K) 	-50 to +1000 °C	$\pm (0.7$ °C +0.3% of mv) (-40 to +900 °C) $\pm (0.9$ °C +0.5% of mv) (remaining range)	0.1 °C (-50 to +199.9 °C) 1.0 °C (remaining range)		
Country versions	Radio freq.	Part no.			
Radio handle for plug-in probe heads, incl. T/C adapter, approval for the countries: DE, FR, UK, BE, NL, ES, IT, SE, AT, DK, FI, HU, CZ, PL, GR, CH, PT, SI, MT, CY, SK, LU, EE, LT, IE, LV, NO	869.85 MHz FSK	0554 0189			
Radio handle for plug-in probe heads, incl. T/C adapter, approval for USA, CA, CL	915.00 MHz FSK	0554 0191			

**Radio probes: General technical data**

	Radio immersion/penetration probe, NTC	Radio handle	Measuring rate	0.5 s or 10 s, adjustable on handle	Radio transmission	Unidirectional
Battery type	2 x 3V button cell (CR 2032)	2 AAA micro batteries	Radio coverage	Up to 20 m (without obstructions)	Oper. temp.	-20 to +50 °C
Battery life	150 h (meas. rate 0.5 s) 2 months (meas. rate 10 s)	215 h (meas. rate 0.5 s) 6 months (meas. rate 10 s)			Storage temp.	-40 to +70 °C



## Custom temperature probes

Do none of the standard temperature probes shown on page 84 and 85 meet your requirements? Or do you already have a clear idea of what your solution should look like? Testo offers temperature probes customized just the way you need them and suited to your application. A few examples are shown on this page. You will find more details on customized temperature probes in the brochure "Stationary Measurement Technology for Air Conditioning and Process".

### Example from mechanical engineering

To create a press fitting between a gear wheel (hub) and shaft, the gear wheel is heated in a furnace until it reaches a certain temperature. The gear wheel is then fitted onto the shaft to which it remains securely joined after cooling down (known as shrink-fit process). To achieve optimum results, the temperature of the gear wheel is checked during this process using a temperature probe attached, for example, to a robotic arm. The spring-loaded tip of the surface temperature probe ensures optimum contact.

### Stationary surface probe with spring-loaded tip

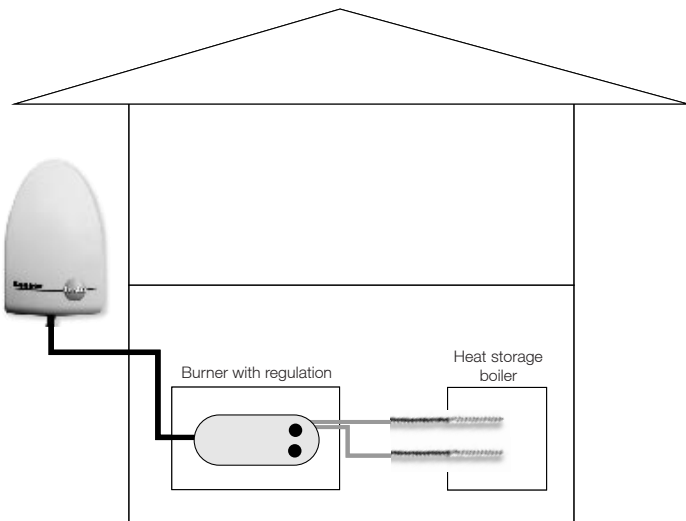
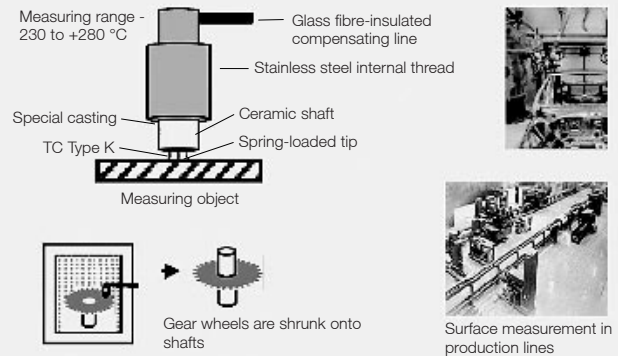

### Example from heating system construction

The regulation and control of a heating system takes place via a temperature comparison. Put simply, the outside temperature and the boiler temperature are compared to one another. Depending on the value recorded, a pump, burner or mixer is switched on or off, for example. But how does the regulator know which boiler temperature needs to be reached at which outside temperature? The regulator uses a defined "heating curve". This determines which boiler temperature must be reached depending on the outside temperature measured. This heating curve thus enables the regulator to judge whether the boiler temperature is too high or too low, in which case a reaction then follows, e.g. the burner fires or is switched off, a pump is switched on, etc.

The **testo probe Type 03** is used to measure the water temperature in the heat storage boiler.

The **testo probe Type 20** measures the outside air temperature.

Measurement probes for immersion in water

0699 4153

### Example from automotive engineering

Recording the temperature of brake discs during travel demands very robust materials. It is also extremely important to have excellent contact with the measuring object so that the actual temperature is recorded. This requirement is met optimally by soldering the thermocouple wire into a nickel turned part by means of a flush front solder.

### Temperature probe for measuring the brake disc temperature

All nickel for a long life of up to 4,000 km

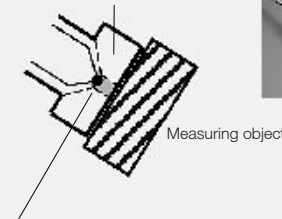

The thermoelectric wires are soldered in. The solder is directly on the measuring object to guarantee optimum temperature recording



#### Probe data

- Type K (class 1) thermocouple
- All-nickel turned part
- Tmax 400 °C
- Glass fibre-insulated steel wire-braided signal line



#### Application

Measuring brake disc temperature during travel

Temperature probe for measuring brake disc temperature

0699 3472



**Always at your service!**

Please send for more information:

Monitoring Instruments for Food Production, Transport and Storage  
Measurement Engineering for Restaurants, Catering and Supermarkets

Measurement Engineering for Air Conditioning and Ventilation  
Measurement Engineering for Heating and Installation

Measurement Solutions for Emissions, Service and Thermal Processes

Measurement Solutions for Refrigeration Technology

Stationary Measurement Solutions for Air Conditioning, Drying, Cleanrooms and Compressed Air

Measurement Solutions for Production, Quality Control and Maintenance

Measurement Solutions for Climate Applications in Industry

Reference Measurement Technology for Industry

Measuring Instruments For Temperature

Measuring Instruments for Humidity

Measuring Instruments For Velocity

Measuring Instruments for Pressure and Refrigeration

Multi-Function Measuring Instruments

Measuring Instruments for Flue Gas and Emissions

Measuring Instruments for RPM, Analysis, Current/Voltage

Measuring Instruments For Indoor Air Quality, Light And Sound

Stationary Measurement Technology Humidity / Differential Pressure / Temperature / Process Displays

Stationary Measurement Technology Compressed Air Humidity / Compressed Air Consumption